

Fitting
Guide

Chemtrol

®

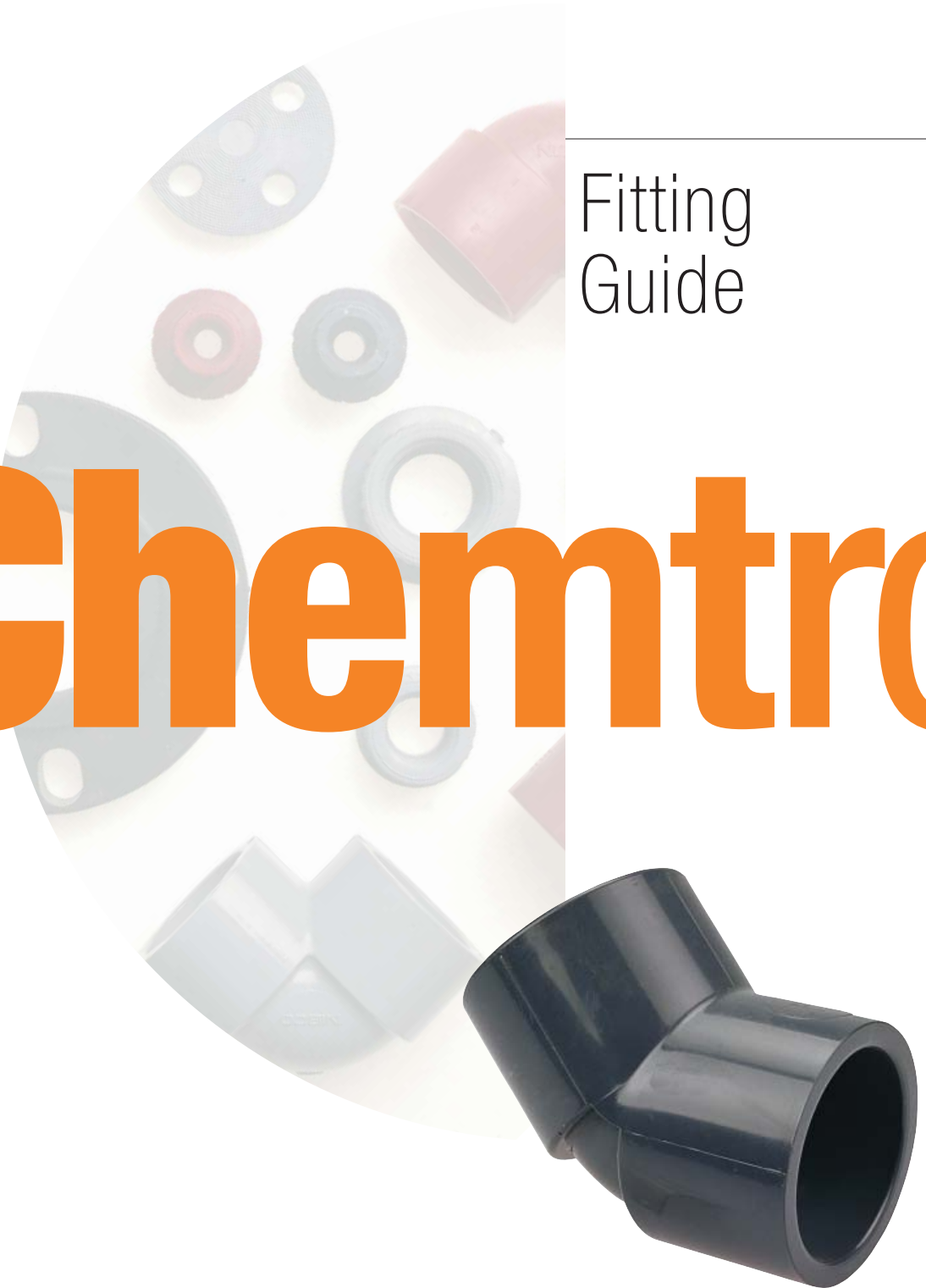

Introduction 2

Introduction to Chemtrol Fittings	2
Materials	2
Fitting Terms and Abbreviations	3
Dimensions and Standards	3

Product Guide 4

PVC Schedule 80	4
Tees	4
Elbows	5
Couplings	6
Adapters	7
Bushings	8
Caps	9
Plugs	10
Class 150 Flanges	10
Unions	12
Transition Unions	13
<hr/>	
Corzan® CPVC Schedule 80	14
Tees	14
Elbows	15
Couplings	16
Adapters	17
Bushings	17
Caps	19
Plugs	19
Class 150 Flanges	19
Unions	22
Transition Unions	23
Nipples	23

Black/Chem-Pure® Natural PP	24
Pipe	24
Tees	24
Elbows	24
Couplings	25
Adapters	26
Bushings	26
Caps	27
Plugs	27
Class 150 Flanges	28
Unions	29
Transition Unions	30
Nipples	30
Kynar® Red and Natural PVDF	31
Pipe/Tees/Elbows	31
Couplings/Adapters	32
Bushings/Caps	33
Plugs/Class 150 Flanges	34
Unions	35
Transition Unions/Nipples	36

Reference Data 37

Standards 41

Warranty 42

Introduction to Chemtrol Fittings

With more than 55 years of experience in industrial thermoplastics, Chemtrol offers dependable products that work in the most demanding environments.

Chemtrol's premium line of quality fittings are lightweight, weather-resistant, and maintenance-free—saving you time and money.

For ideas that fit your flow-control applications, call on Chemtrol—a company committed to superiority in thermoplastic fittings.

Materials

PVC

(Polyvinyl Chloride) PVC conforming to ASTM D-1784 Classification 12454-B, formerly designated Type I, Grade 1, is the most frequently specified of all thermoplastic piping materials. It has been used successfully for over 45 years in such diverse areas as chemical processing, industrial plating, chilled and tower cooling water, deionized water manufacture and distribution, and irrigation sprinkler systems. PVC is characterized by high physical properties and resistance to chemical attack by strong acids and other oxidizers, alkalis, salt solutions, some organic chemical solutions, and many other chemicals. It is attacked, however, by non-ionic surfactants, some vegetable oils (e.g., peanut), and many organic chemicals such as polar solvents (e.g., ketones), aromatics (i.e., benzene ring structure), and chlorinated hydrocarbons. The maximum service temperature of PVC is 140° F. With a design stress of 2,000 psi at 73° F, the long-term hydrostatic strength of PVC is as high as any of the major thermoplastic materials being used for solid piping systems. PVC is joined by solvent cementing, threading, or flanging.

CPVC (Corzan®)

(Chlorinated Polyvinyl Chloride) CPVC conforming to ASTM D-1784 Classification 23447-B, formerly designated Type IV, Grade 1, is a resin created by the post-chlorination of a PVC polymer. The material's resistance to chemical attack is almost identical to that of PVC. And the physical properties of CPVC are very similar to those of PVC at 73° F, but the additional chlorine in the CPVC polymer extends its maximum service temperature from 140° F to 210° F. For example, the design stress for CPVC is 2,000 psi at 73° F, identical to that of PVC. But its strength is only reduced to 500 psi at 180° F, as compared to 440 psi for PVC at 140° F. For more than 35 years, CPVC has proven to be an excellent material for hot corrosive liquids, hot and cold water distribution, and similar applications above the useful temperature range for PVC. CPVC may even be chosen over PVC in the 110° F to 140° F temperature range because its higher strength-at-temperature, requiring less frequent piping supports, can translate to a more favorable overall installed cost than PVC. CPVC is joined by solvent cementing, threading, or flanging.

PVDF (Kynar®)

(Polyvinylidene Fluoride) PVDF homopolymer conforming to ASTM D-3222, Type I, Grade 2, is a tough, abrasion-resistant fluorocarbon material that has a design stress of 1,360 psi at 73° F and a maximum service temperature of 280° F. It has versatile chemical resistance to salts, strong acids, dilute bases, and many organic solvents, such as the aromatics (i.e., benzene ring structure), the aliphatics (i.e., paraffin, olefin, and acetylene hydrocarbons), and the chlorinated groups. And PVDF is ideally suited for handling wet or dry chlorine bromine and other halogens. However, it is attacked by strong bases, hypochlorites, and some organic chemicals such as polar solvents (e.g., ketones) and esters. No other solid thermoplastic piping material can approach the combined strength, working temperature, and chemical resistance characteristics of PVDF. It is joined by the thermo-seal socket fusion process, threading, or flanging.

Since PVDF is transparent to ultraviolet (UV) radiation, the plastic material is not degraded by sunlight. However, the fluid medium in a PVDF piping system will be totally exposed to UV. To provide protection against UV degradation of the fluid medium, an FDA-approved red pigmentation is added to all piping components for general industrial consumption, particularly for outdoor installations. Conversely, in certain industries, such as electronics, pharmaceuticals, and processed foods/beverages, PVDF has become the piping material of choice because of its high purity, low surface and joint extractables, and elevated temperature sanitation capability. For these applications, another line of piping products made from natural (unpigmented) Kynar® is available.

PP

(Polypropylene) PP as specified by ASTM D-4101, is a member of the polyolefin family of pure hydrocarbon plastics. Although PP has half the strength of PVC and CPVC, with a design stress of 1,000 psi at 73° F, it may have the most versatile chemical resistance of the thermoplastic materials identified as the sentinels of industrial piping. Consider the fact that there are no known solvents for PP. As a result, it has been the material of choice for drainage of mixed industrial chemicals for all its 40-year life. As pressure piping, PP has no peers for concentrated acetic acid or hydroxides. It is also suitable for milder solutions of most acids, alkalis, salts, and many organic chemicals, including solvents. The nemeses for PP are strong oxidizers, such as the hypochlorites and higher concentrations of sulfuric, nitric, and hydrofluoric acids. They are Environmental Stress Cracking (ESC) agents for PP, meaning that time-to-failure is a function of the combined variables of concentration and temperature of the fluid and stress in the piping material. Although PP is not recommended for some organic chemicals, such as polar and chlorinated solvents and the aromatics, the concern is permeation through rather than catastrophic damage of the molecular chain.

All polyolefins are severely degraded by ultraviolet (UV) radiation. However, the plastic piping industry recognizes that PP compounds, containing more than 2 1/2% carbon black pigmentation, are adequately UV stabilized to realize an outside service life of more than 25 years. Chemtrol utilizes such a compound to make all piping components for general industrial consumption, particularly for outdoor installations. Because of the high purity and low surface and joint extractables from natural (unpigmented) PP, Chemtrol utilizes an optimum compound to also make piping components for DI water systems. These are intended as an economic alternative to the ultra high purity infrared (IR) butt fusion PVDF systems typically found in the highly sophisticated electronic semi-conductor industry. It has been demonstrated that an appropriately designed serpentine system, constructed by mechanics properly instructed in the heat fusion of socket joints for sanitary piping, can consistently produce water conforming to the quality standards for injectable drugs.

FKM

(Fluoroelastomer) FKM is compatible with a broad spectrum of chemicals. Because of this extensive chemical compatibility, spanning wide ranges of concentration and temperature, FKM has gained wide acceptance as a material of construction for valve "O"-rings and seats. These fluoroelastomers can be used in most applications involving mineral acids (with the exception of HCl), salt solutions, chlorinated hydrocarbons, and petroleum oils. FKM is not recommended for most strong alkali solutions.

EPDM

(Also known as EPT) EPDM produced from ethylene-propylene-diene monomer, is a terpolymer elastomer that has good abrasion and tear resistance and offers excellent chemical resistance to a variety of salt, acidic, and organic chemical solutions. It is the best material for most alkali solutions and hydrochloric acid but is not recommended for applications involving petroleum oils or most strong acids.

PTFE

(Polytetrafluoroethylene) PTFE has outstanding resistance to chemical attack by most chemicals and solvents. PTFE has a temperature rating of -200° F to +500° F. It is a self-lubricating material used as a seat and/or bearing material in most Chemtrol valves.

CR

(Polychloroprene) CR was the first commercial synthetic rubber. It is a moderately oil-resistant material with good general chemical resistance. It is specifically recommended for strong concentrations of alkalis, but not recommended for most organic solvents or any acid solutions, other than dilute.

Kynar® is a registered trademark of Arkema Inc.
Corzan® is a registered trademark of The Lubrizol Corporation.

Do not use or test the products in this catalog with compressed air or other gases.

Fitting Terms and Abbreviations Schedule 80 only

FPT Female Pipe Thread
 CL Close
 MPT Male Pipe Thread
 S Female Socket
 SH Short
 SPG Male End (Spigot)

Dimensions and Standards

Universal Part No.

XX XX - XXX

① ② ④

Chemtrol Part No.

(Discontinued)

XX XXX XXX

① ② ④

Material and Product Type

	①	①	①
Product Line	Universal Part Number	Chemtrol Part Number	Chemtrol Figure Number
PVC Sch. 40	4	08	46
PVC Sch. 80	8	01	45
CPVC Sch. 80	18	05	51
PP Black Sch. 80.	28	07	61
NPP Chem-Pure Sch. 80	78	10	62
PVDF Red Sch. 80	38	58	65
NPVDF Natural Sch. 80	48	06	66

Fitting Description

	②	②	②	③
Fitting & End Connection	Universal Part No.	Chemtrol Part No.	Chemtrol Fitting	Chemtrol Figure No. Connection(s)
Tee-Socket	01	013	00	Blank
Tee-Socket x Thread	02	015	12	Blank
Tee-Thread	05	014	12	3-3
90° ELL-Socket	06	001	07	Blank
90° ELL-Socket x Thread	07	003	07	3
90° ELL-Thread	08	002	07	3-3
90° Street ELL-Male Thread x Socket	10	219	07	4
90° Street ELL-Male Thread x Thread	12	213	07	3-4
45° ELL-Socket	17	007	06	Blank
45° ELL-Thread	19	008	06	3-3
Coupling-Socket	29	025	01	Blank
Coupling-Thread	30	026	01	3-3
Adapter Coupling-Socket x Thread	35	027	03	Blank
Male Adapter-Male Thread x Socket	36	217	04	Blank
Reducing Bushing-Socket	37	049	18	Blank
Reducing Bushing-Spigot x Thread	38	051	18	3
Reducing Bushing-Thread	39	050	18	3-4
Cap-Socket	47	031	17	Blank
Cap-Thread	48	032	17	3
Plug-Spigot	49	042	16	Blank
Plug-Thread	50	043	16	4
Flange-Socket	51	045	51	Blank
Flange-Thread	52	044	51	3
Flange-Blind	53	046	19	Blank
Van Stone Flange-Socket	54	069	51	A
Union-Socket	97	028	33	Blank
Union-Thread	98	029	33	3-3
Nipple-Thread x Thread	61	053	29	Blank

Chemtrol Figure

XX XX - X - X - SIZE

① ② ③ ④

Size Description	④	④	④
Size	Universal Part Number	Chemtrol Part Number	Chemtrol Figure Number
1/4	002	004	Simply State Size
1/2	005	007	
3/4	007	008	
1	010	009	
1 1/4	012	010	
1 1/2	015	011	
2	020	012	
2 1/2	025	013	
3	030	014	
4	040	016	
6	060	018	
8	080	019	
10	100	020	
12	120	021	
1/2 x 1/4	072	027	
3/4 x 1/4	098	029	
3/4 x 1/2	101	031	
1 x 1/4	128	032	
1 x 1/2	130	034	
1 x 3/4	131	035	
1 1/4 x 1/2	166	038	
1 1/4 x 3/4	167	039	
1 1/4 x 1	168	040	
1 1/2 x 1/2	209	043	
1 1/2 x 3/4	210	044	
1 1/2 x 1	211	045	
1 1/2 x 1 1/4	212	046	
2 x 1/2	247	049	
2 x 3/4	248	050	
2 x 1	249	051	
2 x 1 1/4	250	052	
2 x 1 1/2	251	053	
2 1/2 x 1/2	287	056	
2 1/2 x 3/4	288	057	
2 1/2 x 1	289	058	
2 1/2 x 1 1/4	290	059	
2 1/2 x 1 1/2	291	060	
2 1/2 x 2	292	061	
3 x 1	335	066	
3 x 1 1/4	336	067	
3 x 1 1/2	337	068	
3 x 2	338	069	
3 x 2 1/2	339	069	
4 x 2	420	076	
4 x 2 1/2	421	077	
4 x 3	422	078	
6 x 2	528	082	
6 x 3	530	084	
6 x 4	532	085	
8 x 6	585	088	

Do not use or test the products in this catalog with compressed air or other gases.

Tees

Chemtrol
Fig. No.

4511 Socket Tee (S x S x S)

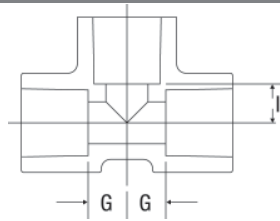

Nominal Size	Universal Part No.	Ctn. Qty.	Approx. Lbs./Ea.	Dim. G	Dim. G	Dim. I
1/4	801-002	25	0.05	0.33	0.33	0.33
1/2	801-005	50	0.15	0.52	0.52	0.52
3/4	801-007	50	0.33	0.69	0.69	0.69
1	801-810	25	0.36	0.75	0.75	0.75
1 1/4	801-012	10	0.44	0.92	0.92	0.92
1 1/2	801-015	25	0.73	1.06	1.06	1.06
2	801-020	20	1.05	1.27	1.27	1.27
2 1/2	801-025	5	1.59	1.53	1.53	1.53
3	801-030	12	2.37	1.84	1.84	1.84
4	801-040	10	4.10	2.34	2.34	2.34
6	801-060	4	10.22	3.50	3.50	3.50
8	801-080	1	21.05	4.56	4.56	4.56
10	801-100	1	35.40	5.75	5.75	5.75
12	801-120	1	58.40	6.89	6.89	6.89

4511 Reducing Socket Tee (S x S x S)

Nominal Size	Universal Part No.	Ctn. Qty.	Approx. Lbs./Ea.	Dim. G	Dim. G	Dim. I
3/4 x 3/4 x 1/2	801-101	25	0.18	0.52	0.52	0.62
1 x 1 x 1/2	801-130	10	0.24	0.53	0.53	0.73
1 x 1 x 3/4	801-131	10	0.26	0.63	0.63	0.74
1 1/2 x 1 1/2 x 3/4	801-210	10	0.48	0.67	0.67	1.05
1 1/2 x 1 1/2 x 1	801-211	10	0.52	0.77	0.77	1.04
2 x 2 x 1/2	801-247	10	0.61	0.61	0.61	1.30
2 x 2 x 3/4	801-248	10	0.65	0.71	0.71	1.30
2 x 2 x 1	801-249	10	0.69	0.81	0.81	1.30
2 x 2 x 1 1/2	801-251	10	0.83	1.08	1.08	1.30
3 x 3 x 2	801-338	5	1.73	1.37	1.37	1.86
4 x 4 x 2	801-420	5	2.79	1.42	1.42	2.36
4 x 4 x 3	801-422	5	3.33	1.90	1.90	2.38
6 x 6 x 4	801-532	4	7.20	2.60	2.60	3.56

4511-12 Flanged Tee

Flanged fitting center-to-face dimensions may be found on page 12. When ordering, specify the figure number and the nominal size (e.g., 2" Schedule 80 PVC flanged tee—4511-12 2")

Chemtrol
Fig. No.

4512 Socket x Thread Tee (S x S x FPT)

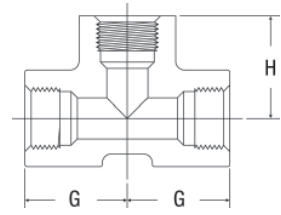

Nominal Size	Universal Part No.	Ctn. Qty.	Approx. Lbs./Ea.	Dim. G	Dim. G	Dim. H
1/2	802-005	10	0.16	0.52	0.52	1.41
3/4	802-007	10	0.24	0.69	0.69	1.71
1	802-010	10	0.34	0.75	0.75	1.89
1 1/4	802-012	10	0.57	0.92	0.92	2.18
1 1/2	802-015	10	0.80	1.06	1.06	2.45
2	802-020	10	1.13	1.27	1.27	2.78

4512-3-3 Threaded Tee (FPT x FPT x FPT)

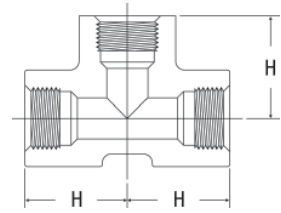

Nominal Size	Universal Part No.	Ctn. Qty.	Approx. Lbs./Ea.	Dim. H
1/4	805-002	25	0.05	0.97
1/2	805-005	25	0.16	1.41
3/4	805-007	25	0.26	1.71
1	805-010	25	0.40	1.89
1 1/4	805-012	10	0.57	2.18
1 1/2	805-015	10	0.80	2.45
2	805-020	10	1.13	2.78
2 1/2	805-025	5	1.79	3.31
3	805-030	5	2.60	3.74
4	805-040	5	4.63	4.62

For questions concerning thermoplastic piping systems, please call or fax: **888.446.4226 (ph)**, **888.336.4226 (fx)**.

Do not use or test the products in this catalog with compressed air or other gases.

Elbows

Chemtrol
Fig. No.

4507 Socket 90° ELL (S x S)

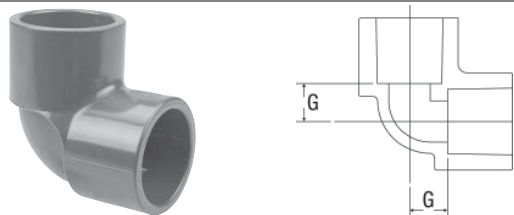

Nominal Size	Universal Part No.	Ctn. Qty.	Approx. Lbs./Ea.	Dim. G
1/4	806-002	25	0.01	0.33
1/2	806-005	50	0.11	0.52
3/4	806-007	50	0.16	0.69
1	806-010	50	0.21	0.75
1 1/4	806-012	25	0.30	0.92
1 1/2	806-015	25	0.50	1.06
2	806-020	25	0.75	1.27
2 1/2	806-025	5	1.16	1.53
3	806-030	12	1.82	1.84
4	806-040	12	3.17	2.34
6	806-060	4	7.70	3.50
8	806-080	2	15.57	4.56
10	806-100	1	27.70	5.75
12	806-120	1	43.90	6.89

4507-3 Socket x Thread 90° ELL (S x FPT)

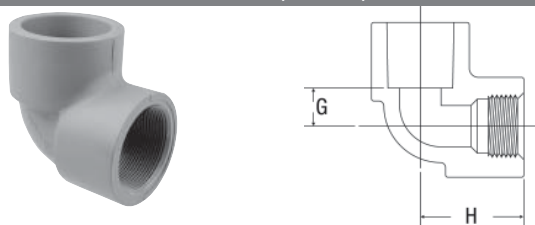

Nominal Size	Universal Part No.	Ctn. Qty.	Approx. Lbs./Ea.	Dim. G	Dim. H
1/2	807-005	10	0.12	0.52	1.41
3/4	807-007	10	0.17	0.69	1.71
1	807-010	10	0.28	0.75	1.89
1 1/4	807-012	10	0.33	0.92	2.18
1 1/2	807-015	10	0.55	1.06	2.45
2	807-020	10	0.82	1.27	2.78

Chemtrol
Fig. No.

4507-3-3 Thread 90° ELL (FPT x FPT)

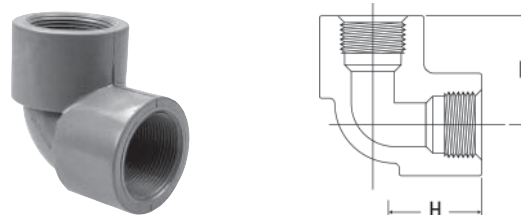

Nominal Size	Universal Part No.	Ctn. Qty.	Approx. Lbs./Ea.	Dim. H
1/4	808-002	25	0.04	0.97
1/2	808-005	25	0.12	1.41
3/4	808-007	25	0.18	1.71
1	808-010	25	0.28	1.89
1 1/4	808-012	10	0.33	2.18
1 1/2	808-015	10	0.55	2.45
2	808-020	10	0.82	2.78
2 1/2	808-025	5	1.25	3.31
3	808-030	5	1.90	3.74
4	808-040	5	3.62	4.62

4506 Socket 45° ELL (S x S)

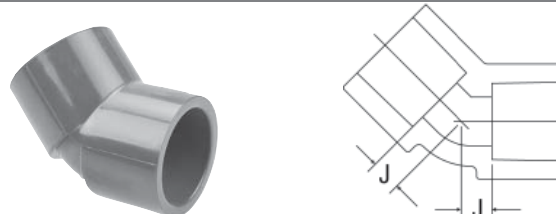

Nominal Size	Universal Part No.	Ctn. Qty.	Approx. Lbs./Ea.	Dim. J
1/4	817-002	15	0.03	0.18
1/2	817-005	25	0.04	0.26
3/4	817-007	25	0.14	0.33
1	817-010	25	0.15	0.37
1 1/4	817-012	10	0.30	0.43
1 1/2	817-015	10	0.41	0.47
2	817-020	10	0.62	0.61
2 1/2	817-025	5	0.93	0.68
3	817-030	6	1.39	0.78
4	817-040	6	2.46	1.02
6	817-060	4	5.82	1.75
8	817-080	2	12.67	2.22
10	817-100	1	19.70	2.61
12	817-120	1	32.70	3.08

Do not use or test the products in this catalog with compressed air or other gases.

Chemtrol
Fig. No.

4506-3-3 Thread 45° ELL (FPT x FPT)

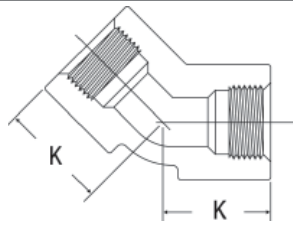

Nominal Size	Universal Part No.	Ctn. Qty.	Approx. Lbs./Ea.	Dim. K
1/4	819-002	15	0.04	0.82
1/2	819-005	25	0.11	1.15
3/4	819-007	25	0.13	1.35
1	819-010	25	0.25	1.51
1 1/4	819-012	10	0.35	1.70
1 1/2	819-015	10	0.48	1.86
2	819-020	10	0.71	2.13
2 1/2	819-025	5	1.03	2.46
3	819-030	6	1.53	2.69
4	819-040	6	2.52	3.30

Couplings

4501 Socket Coupling (S x S)

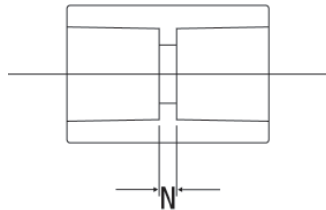

Nominal Size	Universal Part No.	Ctn. Qty.	Approx. Lbs./Ea.	Dim. N
1/4	829-002	25	0.05	0.12
1/2	829-005	50	0.09	0.25
3/4	829-007	50	0.13	0.25
1	829-010	40	0.20	0.25
1 1/4	829-012	25	0.29	0.25
1 1/2	829-015	20	0.37	0.25
2	829-020	25	0.52	0.25
2 1/2	829-025	5	1.68	0.20
3	829-030	12	1.05	0.19
4	829-040	10	1.83	0.19
6	829-060	4	4.07	0.25
8	829-080	2	8.89	0.25
10	829-100	1	13.88	0.38
12	829-120	1	21.37	0.50

Chemtrol
Fig. No.

4501 Reducing Socket Coupling (S x S)

Nominal Size	Universal Part No.	Ctn. Qty.	Approx. Lbs./Ea.	Dim. N
3/4 x 1/2	829-101	25	0.12	0.44
1 x 1/2	829-130	25	0.18	0.67
1 x 3/4	829-131	25	0.19	0.55
1 1/4 x 3/4	829-167	25	0.26	0.72
1 1/4 x 1	829-168	10	0.27	0.60
1 1/2 x 3/4	829-210	10	0.31	0.76
1 1/2 x 1	829-211	10	0.33	0.63
1 1/2 x 1 1/4	829-212	10	0.50	0.51
2 x 1	829-249	10	0.44	0.75
2 x 1 1/2	829-251	10	0.50	0.50
3 x 2	829-338	5	1.00	1.24
4 x 2	829-420	5	1.59	1.59
4 x 3	829-422	5	1.88	1.20

Other Reducing Couplings are produced by solvent cementing appropriate Reducer Bushings into Socket Couplings. They may be ordered as factory fabrications or may be assembled in the field.

4501-3-3 Thread Coupling (FPT x FPT)

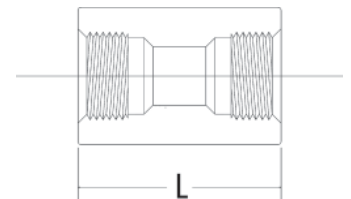

Nominal Size	Universal Part No.	Ctn. Qty.	Approx. Lbs./Ea.	Dim. L
1/4	830-002	25	0.06	1.41
1/2	830-005	25	0.09	2.03
3/4	830-007	25	0.14	2.28
1	830-010	25	0.23	2.53
1 1/4	830-012	10	0.33	2.78
1 1/2	830-015	10	0.41	3.03
2	830-020	10	0.60	3.28
2 1/2	830-025	5	0.86	3.76
3	830-030	5	1.22	4.00
4	830-040	5	2.13	4.75

Do not use or test the products in this catalog with compressed air or other gases.

Chemtrol
Fig. No.

4501-3-3 Reducing Thread Coupling (FPT x FPT)

Nominal Size	Universal Part No.	Ctn. Qty.	Approx. Lbs./Ea.	Dim. L
3/4 x 1/2	830-101	25	0.09	2.34
1 x 1/2	830-130	25	0.20	2.70
1 x 3/4	830-131	25	0.18	2.70
1 1/4 x 3/4	830-167	10	0.29	3.00
1 1/4 x 1	830-168	10	0.31	3.00
1 1/2 x 3/4	830-210	10	0.35	3.16
1 1/2 x 1	830-211	10	0.38	3.16
1 1/2 x 1 1/4	830-212	10	0.40	3.16
2 x 1	830-249	10	0.50	3.40
2 x 1 1/2	830-251	10	0.56	3.40
3 x 2	830-338	5	1.15	4.66
4 x 2	830-420	5	1.79	5.38
4 x 3	830-422	5	2.11	5.38

Other Reducing Couplings are produced by solvent cementing appropriate Reducer Bushings into Socket Couplings. They may be ordered as factory fabrications or may be assembled in the field.

Adapters

4503 Female Adapter Coupling (S x FPT)

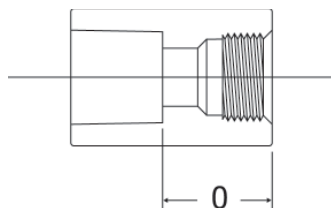

Nominal Size	Universal Part No.	Ctn. Qty.	Approx. Lbs./Ea.	Dim. O
1/4	835-002	15	0.04	0.77
1/2	835-005	25	0.09	1.14
3/4	835-007	25	0.14	1.27
1	835-010	20	0.21	1.39
1 1/4	835-012	10	0.30	1.52
1 1/2	835-015	10	0.38	1.64
2	835-020	10	0.56	1.77
2 1/2	835-025	5	0.77	1.98
3	835-030	5	1.15	2.10
4	835-040	5	1.95	2.47

Chemtrol
Fig. No.

4504 Male Adapter (S x MPT)

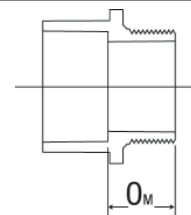

Nominal Size	Universal Part No.	Ctn. Qty.	Approx. Lbs./Ea.	Dim. O _M
1/2	836-005	25	0.04	0.94
3/4	836-007	25	0.06	0.97
1	836-010	25	0.10	1.15
1 1/4	836-012	10	0.14	1.12
1 1/2	836-015	10	0.19	1.12
2	836-020	10	0.27	1.20
2 1/2	836-025	5	0.56	1.89
3	836-030	5	0.79	1.99
4	836-040	5	1.39	2.09

4550 Tank Adapter (Tank x FPT)

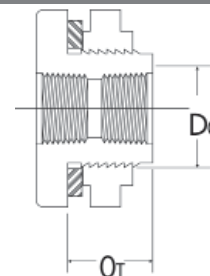

Nominal Size	Universal Part No.	Ctn. Qty.	Approx. Lbs./Ea.	Dim. O _T	Dim. D _O
1/2		15	0.17	1.38	1.40
3/4	Use	15	0.23	1.38	1.40
1	Figure	15	0.27	1.90	2.28
1 1/4	No. &	10	0.42	1.90	2.28
1 1/2	Nom.	10	0.34	2.19	3.00
2	Size	5	1.04	2.19	3.00
3		5	2.33	3.40	5.70

Note: Gasket is EPDM and nut is self-tightening left hand thread.

For complete technical information and more, refer to our website at www.chemtrol.com.

Do not use or test the products in this catalog with compressed air or other gases.

Bushings

Design Styles

The design style of most bushings is to have a solid wall between the inside and outside connections. Some of the multistep reductions with exceedingly thick cross-sections are not solid. This design style achieves structural support with a web of ribs attaching the inner and outer connection walls, with the open area toward the exterior bushing face. The styles are denoted by W and S for webbed and solid designs respectively.

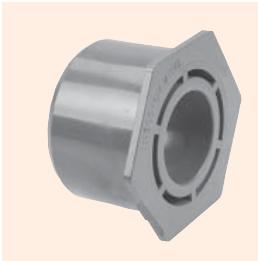

Webbed design

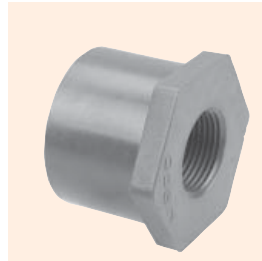

Solid design

Chemtrol
Fig. No.

4518 Flush Socket Reducer Bushing (SPG x S)

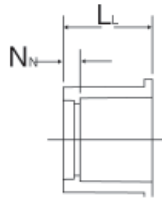

Nominal Size	Universal Part No.	Ctn. Qty.	Approx. Lbs./Ea.	Design Style	Dim. L _L	Dim. N _N
1/2 x 1/4	837-072	50	0.03	S	1.17	0.53
3/4 x 1/2	837-101	50	0.05	S	1.15	0.26
1 x 1/2	837-130	50	0.06	S	1.28	0.39
1 x 3/4	837-131	50	0.05	S	1.28	0.27
1 1/4 x 1/2	837-166	10	0.10	S	1.41	0.52
1 1/4 x 3/4	837-167	10	0.05	S	1.41	0.40
1 1/4 x 1	837-168	10	0.06	S	1.41	0.27
1 1/2 x 1/2	837-209	25	0.12	W	1.53	0.64
1 1/2 x 3/4	837-210	25	0.10	S	1.53	0.52
1 1/2 x 1	837-211	25	0.08	S	1.53	0.39
1 1/2 x 1 1/4	837-212	10	0.06	S	1.53	0.27
2 x 1/2	837-247	25	0.25	S	1.66	0.77
2 x 3/4	837-248	25	0.25	S	1.66	0.65
2 x 1	837-249	25	0.25	W	1.66	0.52
2 x 1 1/4	837-250	10	0.22	W	1.66	0.40
2 x 1 1/2	837-251	25	0.20	W	1.66	0.27
2 1/2 x 1	837-289	10	0.31	W	1.94	0.80
2 1/2 x 1 1/4	837-290	10	0.31	W	1.94	0.68
2 1/2 x 1 1/2	837-291	10	0.27	S	1.94	0.55
2 1/2 x 2	837-292	10	0.24	S	1.94	0.43
3 x 1	837-335	10	0.65	W	2.42	1.28
3 x 1 1/2	837-337	10	0.67	W	2.42	1.03
3 x 2	837-338	10	0.64	S	2.42	0.91
3 x 2 1/2	837-339	10	0.48	S	2.42	0.64

Chemtrol
Fig. No.

4518 Flush Socket Reducer Bushing (SPG x S) (cont.)

Nominal Size	Universal Part No.	Ctn. Qty.	Approx. Lbs./Ea.	Design Style	Dim. L _L	Dim. N _N
4 x 2	837-420	10	1.14	W	2.81	1.30
4 x 2 1/2	837-421	5	1.14	W	2.81	1.03
4 x 3	837-422	10	0.93	S	2.81	0.91
6 x 2	837-528	5	3.28	W	3.06	1.55
6 x 4	837-532	10	2.68	S	3.06	0.78
8 x 6	837-585	3	5.51	S	4.59	1.56
10 x 6	837-626	1	10.68	W	5.59	2.56
10 x 8	837-628	1	9.36	S	5.59	1.09
12 x 8	837-668	1	16.73	W	6.59	2.09
12 x 10	837-670	1	12.77	S	6.59	1.09

Other Reducing Couplings are produced by solvent cementing appropriate Reducer Bushings into Socket Couplings. They may be ordered as factory fabrications or may be assembled in the field.

4518-3 Flush Spigot x Thread Reducer Bushing (SPG x FPT)

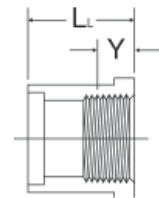

Nominal Size	Universal Part No.	Ctn. Qty.	Approx. Lbs./Ea.	Design Style	Dim. L _L	Dim. Y*
1/2 x 1/4	838-072	50	0.03	S	1.17	0.31
3/4 x 1/4	838-098	50	0.04	S	1.29	0.31
3/4 x 1/2	838-101	50	0.03	S	1.29	0.43
1 x 1/2	838-130	50	0.07	S	1.56	0.43
1 x 3/4	838-131	50	0.05	S	1.56	0.45
1 1/4 x 1/2	838-166	10	0.14	S	1.66	0.43
1 1/4 x 3/4	838-167	10	0.12	S	1.66	0.45
1 1/4 x 1	838-168	10	0.10	S	1.66	0.53
1 1/2 x 1/2	838-209	10	0.21	S	1.78	0.43
1 1/2 x 3/4	838-210	10	0.19	S	1.78	0.45
1 1/2 x 1	838-211	5	0.17	S	1.78	0.53
1 1/2 x 1 1/4	838-212	10	0.12	S	1.78	0.55
2 x 1/2	838-247	10	0.34	S	1.92	0.43
2 x 3/4	838-248	10	0.32	S	1.92	0.45
2 x 1	838-249	10	0.29	S	1.92	0.53
2 x 1 1/4	838-250	10	0.24	S	1.92	0.55
2 x 1 1/2	838-251	10	0.20	S	1.92	0.55
2 1/2 x 2	838-292	5	0.25	S	2.18	0.57
3 x 1	838-335	5	0.65	S	2.42	0.53
3 x 1 1/2	838-337	5	0.70	S	2.42	0.55
3 x 2	838-338	5	0.67	S	2.42	0.57
3 x 2 1/2	838-339	5	0.52	S	2.42	0.87
4 x 2	838-420	5	1.17	S	2.81	0.57
4 x 3	838-422	5	1.01	S	2.81	0.95

Other size reductions are produced by solvent cementing appropriate Reducer Bushings together. They may be ordered as factory fabrications or may be assembled in the field.

*Typical male component engagement, hand tight (L₁ in ANSI B1.20.1 thread spec.) plus 1 1/2 turns.

Do not use or test the products in this catalog with compressed air or other gases.

Chemtrol
Fig. No.

4518-3-4 Flush Thread Reducer Bushing (MPT x FPT)

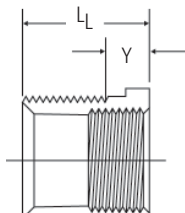

Nominal Size	Universal Part No.	Ctn. Qty.	Approx. Lbs./Ea.	Design Style	Dim. L L	Dim. Y*
1/2 x 1/4	839-072	50	0.02	S	0.93	0.25
3/4 x 1/4	839-098	50	0.03	S	0.95	0.25
3/4 x 1/2	839-101	50	0.02	S	0.95	0.25
1 x 1/2	839-130	50	0.05	S	1.24	0.38
1 x 3/4	839-131	50	0.03	S	1.24	0.38
1 1/4 x 1/2	839-166	10	0.10	S	1.27	0.38
1 1/4 x 3/4	839-167	10	0.09	S	1.27	0.38
1 1/4 x 1	839-168	10	0.07	S	1.27	0.38
1 1/2 x 1/2	839-209	10	0.15	S	1.28	0.38
1 1/2 x 3/4	839-210	10	0.14	S	1.28	0.38
1 1/2 x 1	839-211	5	0.12	S	1.28	0.38
1 1/2 x 1 1/4	839-212	10	0.08	S	1.28	0.38
2 x 1/2	839-247	10	0.23	S	1.32	0.38
2 x 3/4	839-248	10	0.22	S	1.32	0.38
2 x 1	839-249	10	0.20	S	1.32	0.38
2 x 1 1/4	839-250	10	0.16	S	1.32	0.38
2 x 1 1/2	839-251	10	0.12	S	1.32	0.38
2 1/2 x 2	839-292	5	0.21	S	2.18	0.57
3 x 1 1/2	839-337	5	0.58	S	2.42	0.55
3 x 2	839-338	5	0.56	S	2.42	0.57
3 x 2 1/2	839-339	5	0.45	S	2.42	0.87
4 x 2	839-420	5	1.09	S	2.81	0.57
4 x 3	839-422	5	0.81	S	2.81	0.95

Other size reductions are produced by solvent cementing appropriate Reducer Bushings together. They may be ordered as factory fabrications or may be assembled in the field.

*Typical male component engagement, hand tight (L₁ in ANSI B1.20.1 thread spec.) plus 1 1/2 turns.

Caps

Chemtrol
Fig. No.

4517 Socket Cap* (S)

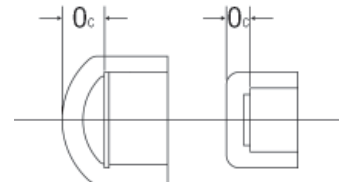

Nominal Size	Universal Part No.	Ctn. Qty.	Approx. Lbs./Ea.	Dim. O _c
1/4	847-002	15	0.03	0.25
1/2	847-005	25	0.06	0.39
3/4	847-007	25	0.08	0.37
1	847-010	25	0.14	0.41
1 1/4	847-012	10	0.20	0.40
1 1/2	847-015	10	0.26	0.41
2	847-020	10	0.38	0.42
2 1/2	847-025	5	0.57	0.57
3	847-030	5	0.87	1.29
4	847-040	5	1.53	1.58
6	847-060	5	3.77	2.13

*Sizes 2" and smaller are flat; 2 1/2" and larger are domed.

4517-3 Thread Cap* (FPT)

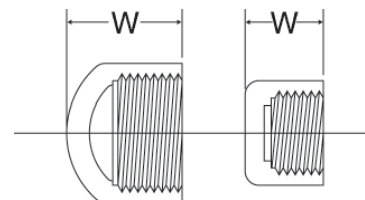
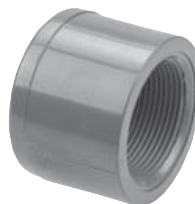

Nominal Size	Universal Part No.	Ctn. Qty.	Approx. Lbs./Ea.	Dim. W
1/4	848-002	15	0.01	0.89
1/2	848-005	25	0.06	1.28
3/4	848-007	25	0.10	1.38
1	848-010	25	0.15	1.55
1 1/4	848-012	10	0.22	1.66
1 1/2	848-015	10	0.29	1.80
2	848-020	10	0.41	1.93
2 1/2	848-025	5	0.64	2.35
3	848-030	5	0.93	3.19
4	848-040	5	1.73	3.86

*Sizes 2" and smaller are flat; 2 1/2" and larger are domed.

Do not use or test the products in this catalog with compressed air or other gases.

Plugs

Chemtrol
Fig. No.

4516-4 Thread Plug (MPT)

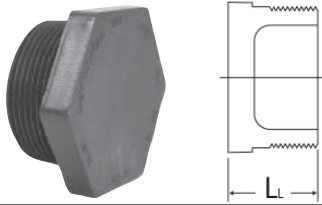

Nominal Size	Universal Part No.	Ctn. Qty.	Approx. Lbs./Ea.	Dim. Ll
1/4	850-002	25	0.01	0.85
1/2	850-005	50	0.03	1.04
3/4	850-007	50	0.03	1.10
1	850-010	25	0.06	1.25
1 1/4	850-012	10	0.10	1.66
1 1/2	850-015	10	0.14	1.78
2	850-020	10	0.19	1.92
2 1/2	850-025	5	0.29	2.18
3	850-030	5	0.51	2.42
4	850-040	5	0.95	2.81

1/4" Plug is solid, only

Class 150 Flanges

For flange dimensions that comply with ANSI B16.5, 150 lb., steel flanges, see page 39.

4551-W Socket Flange (S), One-Piece (Webbed Design)

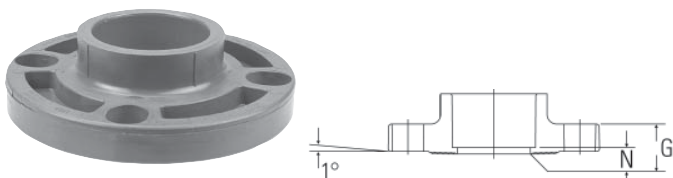

Nominal Size	Universal Part No.	Ctn. Qty.	Approx. Lbs./Ea.	Dim. G	Dim. N
2	851-020	12	0.79	0.92	0.27
3	851-030	10	1.60	1.13	0.29
4	851-040	10	2.42	1.24	0.32
6	851-060	5	3.69	1.36	0.31

Reducing Flanges are produced by solvent cementing Reducer Bushings into Socket Flanges. They may be ordered as factory fabrications or may be assembled in the field.

Note: One-piece webbed flanges have oblong bolt holes which permit mating with ANSI B16.5, 150 lb.; BS 1560, class 150; ISO 2084, PN10; and DIN 2532, PN10 flanges.

Chemtrol
Fig. No.

4551-H Socket Flange (S), One-Piece (Solid)

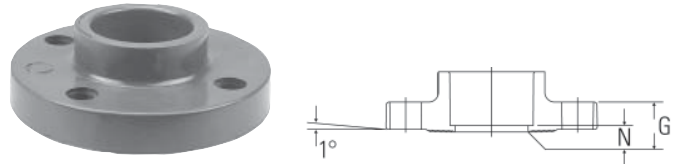

Nominal Size	Universal Part No.	Ctn. Qty.	Approx. Lbs./Ea.	Dim. G	Dim. N
1/2	851-H05	10	0.21	0.54	0.20
3/4	851-H07	10	0.31	0.61	0.17
1	851-H10	24	0.41	0.68	0.18
1 1/4	851-H12	10	0.53	0.73	0.20
1 1/2	851-H15	12	0.68	0.82	0.23
2	851-H20	12	1.03	0.92	0.27
2 1/2	851-H25	5	1.61	1.02	0.20
3	851-H30	10	2.08	1.13	0.29
4	851-H40	10	3.14	1.24	0.32
6	851-H60	5	4.79	1.36	0.31
8	851-H80	2	8.67	1.50	0.35

Reducing Flanges are produced by solvent cementing Reducer Bushings into Socket Flanges. They may be ordered as factory fabrications or may be assembled in the field.

4551-W-3 Thread Flange (FPT), One-Piece (Webbed Design)

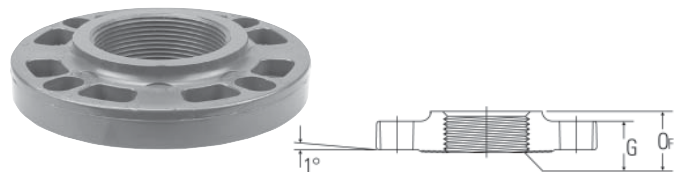

Nominal Size	Universal Part No.	Ctn. Qty.	Approx. Lbs./Ea.	Dim. G	Dim. Of
2	852-020	10	0.78	0.92	1.18
3	852-030	5	1.54	1.13	1.55
4	852-040	5	2.25	1.24	1.67

Reducing Flanges are produced by solvent cementing Reducer Bushings into Socket Flanges. They may be ordered as factory fabrications or may be assembled in the field.

Note: One-piece webbed flanges have oblong bolt holes which permit mating with ANSI B16.5, 150 lb.; BS 1560, class 150; ISO 2084, PN10; and DIN 2532, PN10 flanges.

Do not use or test the products in this catalog with compressed air or other gases.

Chemtrol
Fig. No.

4551-H-3 Thread Flange (FPT), One-Piece (Solid)

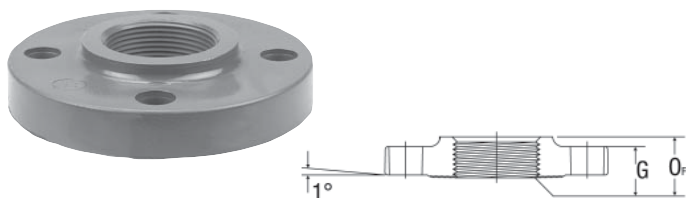

Nominal Size	Universal Part No.	Ctn. Qty.	Approx. Lbs./Ea.	Dim. G	Dim. OF
1/2	852-H05	10	0.21	0.54	0.88
3/4	852-H07	10	0.30	0.61	0.91
1	852-H10	10	0.40	0.68	1.08
1 1/4	852-H12	10	0.50	0.73	1.11
1 1/2	852-H15	12	0.65	0.82	1.12
2	852-H20	10	0.97	0.92	1.18
2 1/2	852-H25	5	1.50	1.02	1.42
3	852-H30	5	1.93	1.13	1.55
4	852-H40	5	2.80	1.24	1.67

Reducing Flanges are produced by solvent cementing Reducer Bushings into Socket Flanges. They may be ordered as factory fabrications or may be assembled in the field.

4519-W Blind Flange, One-Piece (Webbed Design)

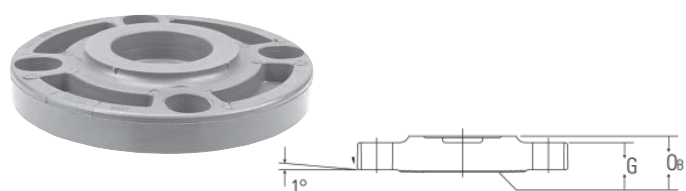

Nominal Size	Universal Part No.	Ctn. Qty.	Approx. Lbs./Ea.	Dim. G	Dim. OB
2	853-020	12	0.78	0.92	1.13
3	853-030	10	1.76	1.13	1.39
4	853-040	5	2.56	1.24	1.51
6	853-060	5	4.51	1.36	1.60

Note: One-piece webbed flanges have oblong bolt holes which permit mating with ANSI B16.5, 150 lb.; BS 1560, class 150; ISO 2084, PN10; and DIN 2532, PN10 flanges.

*Chemtrol sells its products through a select group of highly trained distributors. Please call **800.343.5455** for a listing of distributors in your area.*

Chemtrol
Fig. No.

4519-H Blind Flange, One-Piece (Solid)

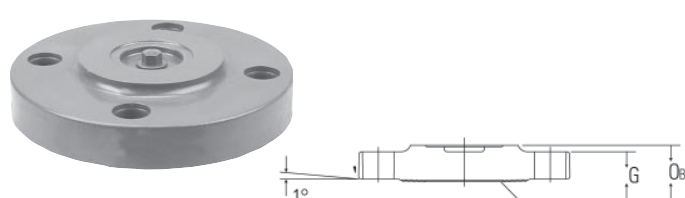

Nominal Size	Universal Part No.	Ctn. Qty.	Approx. Lbs./Ea.	Dim. G	Dim. OB
1/2	853-H05	10	0.21	0.54	0.76
3/4	853-H07	10	0.32	0.61	0.83
1	853-H10	10	0.43	0.68	0.88
1 1/4	853-H12	10	0.57	0.73	0.95
1 1/2	853-H15	12	0.69	0.82	1.04
2	853-H20	12	1.08	0.92	1.13
2 1/2	853-H25	5	1.81	1.02	1.22
3	853-H30	10	2.45	1.13	1.39
4	853-H40	5	3.56	1.24	1.51
6	853-H60	5	6.27	1.36	1.60
8	853-H80	2	10.35	1.50	1.78

4551-A Socket Flange (S), Van Stone

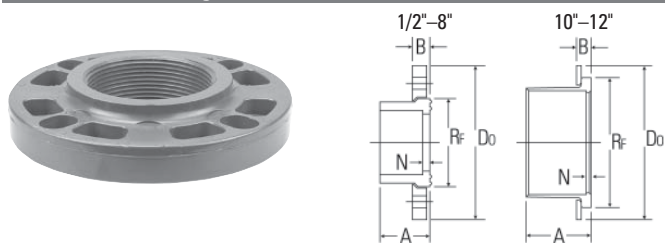

Nominal Size	Universal Part No.	Ctn. Qty.	Approx. Lbs./Ea.	Dim. A	Dim. B	Dim. Do	Dim. Rf	Dim. N
1/2	854-005	10	0.19	1.00	.50	3.50	1.48	0.11
3/4	854-007	10	0.24	1.13	.50	3.88	1.75	0.11
1	854-010	24	0.38	1.25	.56	4.25	2.04	0.11
1 1/4	854-012	10	0.40	1.38	.63	4.63	2.50	0.11
1 1/2	854-015	12	0.54	1.50	.69	5.00	2.78	0.11
2	854-020	12	0.92	1.63	.75	6.00	3.41	0.11
2 1/2	854-025	5	1.37	1.94	.94	7.00	4.11	0.16
3	854-030	10	1.75	2.40	1.05	7.50	4.81	0.50
4	854-040	10	2.65	2.76	1.16	8.98	6.19	0.48
6	854-060	5	4.53	3.56	1.29	11.00	7.97	0.53
8	854-080	2	12.20	5.01	1.42	13.50	10.45	0.51
10*	854-100	1	10.20	5.83	1.31	16.00	13.29	0.33
12*	854-120	1	17.53	7.45	1.70	19.00	16.00	0.45

*Aluminum ring with PVC coating.

Van Stone Flange Assembly List

Item	Description	Material
1	Connector Hub	PVC
2	Flange Ring	PVC Coated Aluminum
3	Flange Ring	PVC

Do not use or test the products in this catalog with compressed air or other gases.

Chemtrol
Fig. No.

NR 51 Flange Gaskets, for Class 150 Flanges



Note: These gaskets are 1/8" thick, full face polychloroprene (CR), 70 durometer.

Nominal Size	Part No.	Approx. Lbs./Ea.
1/2	Use Figure No. & Nom. Size	0.11
3/4		0.12
1		0.13
1 1/4		0.14
1 1/2		0.15
2		0.20
2 1/2		0.25
3		0.28
4		0.30
6		0.40
8		0.50
10		0.55
12	0.60	

Flanged Fittings*— Fabricated from Molded Components

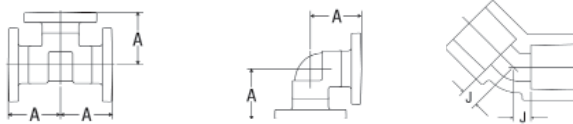

Nominal Size	Fig. No. 4511-12 Flanged Tee		Fig. No. 4507-12 Flanged 90° ELL		Fig. No. 4506-12 Flanged 45° ELL	
	Approx. Lbs./Ea.	Dim. A	Approx. Lbs./Ea.	Dim. A	Approx. Lbs./Ea.	Dim. B
1	1.71	3 3/32	1.19	3 3/32	1.12	2 23/32
1 1/4	2.39	3 19/32	1.60	3 19/32	1.60	3 3/32
1 1/2	3.24	3 31/32	2.06	3 31/32	2.09	3 13/32
2	4.86	4 15/32	3.28	4 15/32	3.16	3 27/32
2 1/2	7.82	5 7/32	5.30	5 7/32	5.08	4 13/32
3	10.67	5 13/32	7.32	5 13/32	6.92	4 25/32
4	16.64	7 3/32	11.60	7 3/32	10.79	5 25/32
6	32.74	9 25/32	22.65	9 25/32	20.84	8 1/2
8	65.79	13 31/32	45.40	13 31/32	42.50	11 5/8

*Flanged fittings are produced by solvent cementing socket flanges to socket fittings with short plain end pipe nipples. They may be ordered as factory fabrications or may be assembled in the field.

Unions

4533 FKM/4533E (EPDM) Socket Union (S x S)

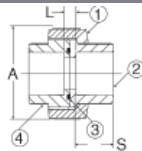

Nominal Size	FKM Part No.	EPDM Part No.	Ctn. Qty.	Approx. Lbs./Ea.	Dim. A	Dim. L	Dim. S*	Dim. T†
1/4	897-002	897E002	10	0.07	1.70	0.40	0.64	
1/2	897-005	897E005	10	0.16	2.00	0.43	0.89	
3/4	897-007	897E007	10	0.27	2.44	0.45	1.01	
1	897-010	897E010	10	0.40	2.83	0.43	1.14	
1 1/4	897-012	897E012	5	0.87	4.08	0.79	1.26	
1 1/2	897-015	897E015	10	0.93	4.08	0.80	1.39	
2	897-020	897E020	10	1.83	5.26	0.80	1.51	
3	897-030	897E030	5	3.47	7.17	0.90	1.90	

The 2 1/2" Socket Union is available as a fabrication from the 3" size Bushed down.

* Socket Depth

Chemtrol
Fig. No.

4533-3-3 FKM / 4533E-3-3 (EPDM) Threaded Union (FPT x FPT)

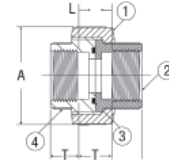

Nominal Size	FKM Part No.	EPDM Part No.	Ctn. Qty.	Approx. Lbs./Ea.	Dim. A	Dim. L	Dim. T*
1/4	898-002	898E002	10	0.11	1.70	1.07	0.31
1/2	898-005	898E005	10	0.16	2.00	1.30	0.43
3/4	898-007	898E007	10	0.28	2.44	1.38	0.45
1	898-010	898E010	10	0.41	2.83	1.51	0.53
1 1/4	898-012	898E012	5	0.90	4.08	2.01	0.55
1 1/2	898-015	898E015	10	0.92	4.08	2.16	0.55
2	898-020	898E020	10	1.82	5.26	2.36	0.57
3	898-030	898E030	5	3.47	7.17	2.88	0.95

The 2 1/2" Thread Union is available as a fabrication from the 3" size Bushed down.

* Thread Joint Engagement

4533E-3 FKM / 4533E-3 (EPDM) Female Adapter Union (S x FPT)

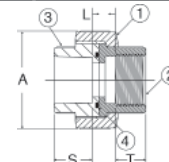
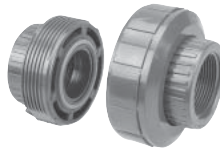

Nominal Size	FKM Part No.	EPDM Part No.	Ctn. Qty.	Approx. Lbs./Ea.	Dim. A	Dim. L	Dim. S*	Dim. T†
1/2	899-005	899E005	10	0.16	2.00	0.84	0.89	0.43
3/4	899-007	899E007	10	0.26	2.44	0.82	1.02	0.45
1	899-010	899E010	10	0.38	2.83	0.90	1.14	0.53
1 1/4	899-012	899E012	10	0.89	4.08	1.29	1.27	0.55
1 1/2	899-015	899E015	10	0.91	4.08	1.32	1.39	0.55
2	899-020	899E020	5	1.81	5.26	1.41	1.51	0.57
3	899-030	899E030	5	3.86	7.17	1.93	1.91	0.95

The 2 1/2" Socket x Thread Union is available as a fabrication from the 3" size Bushed down.

* Socket Depth

† Thread Joint Engagement

Do not use or test the products in this catalog with compressed air or other gases.

Transition Unions

Purchase and Assembly Instructions

Transition Unions result from field assembly. First, the basic plastic Union is chosen, which includes selections for material of construction, O-ring type and connection style, remembering that the Union Nut screws onto the plastic Union Tailpiece. Next, the metal End Connector is chosen for material type and choice of thread connection style. Prior to installation, the mechanic must disassemble the Union, remove and discard the plastic End Connector, and then reassemble with the metal End Connector in its place.

Chemtrol
Fig. No.

TCBR-3 Brass End Connector (FPT)



Nominal Size	Universal Part No.	Ctn. Qty.	Approx. Lbs./Ea.	Dim. A	Dim. T*
1/2	↑	1	0.33	1.02	0.43
3/4	↑	1	0.43	1.02	0.45
1	Use Fig. No.	1	0.52	1.19	0.53
1 1/4	& Nom. Size	1	0.85	1.42	0.55
1 1/2	↓	1	1.81	1.42	0.55
2	↓	1	2.74	1.57	0.57
3	↓	1	5.45	2.25	0.95

* Thread Joint Engagement

TCSS-3 Stainless Steel End Connector (FPT)

Nominal Size	Universal Part No.	Ctn. Qty.	Approx. Lbs./Ea.	Dim. A	Dim. T*
1/2	↑	1	0.30	1.02	0.43
3/4	↑	1	0.39	1.02	0.45
1	Use Fig. No.	1	0.47	1.19	0.53
1 1/4	& Nom. Size	1	0.77	1.42	0.55
1 1/2	↓	1	1.64	1.42	0.55
2	↓	1	2.48	1.57	0.57
3	↓	1	4.97	2.25	0.95

* Thread Joint Engagement

TCBR-4 Brass End Connector (MPT) Brass End Connector (MPT)

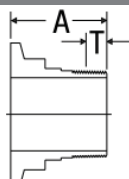

Nominal Size	Universal Part No.	Ctn. Qty.	Approx. Lbs./Ea.	Dim. A	Dim. T*
1/2	↑	1	0.31	1.66	0.43
3/4	↑	1	0.41	1.69	0.45
1	Use Fig. No.	1	0.49	2.19	0.53
1 1/4	& Nom. Size	1	0.81	2.38	0.55
1 1/2	↓	1	1.72	2.38	0.55
2	↓	1	2.60	2.63	0.57
3	↓	1	5.45	3.50	0.95

* Thread Joint Engagement

Chemtrol
Fig. No.

TCSS-4 Stainless Steel End Connector (MPT)

Nominal Size	Universal Part No.	Ctn. Qty.	Approx. Lbs./Ea.	Dim. A	Dim. T*
1/2	↑	1	0.28	1.66	0.43
3/4	↑	1	0.37	1.69	0.45
1	Use Fig. No.	1	0.44	2.19	0.53
1 1/4	& Nom. Size	1	0.73	2.38	0.55
1 1/2	↓	1	1.56	2.38	0.55
2	↓	1	2.36	2.63	0.57
3	↓	1	4.97	3.50	0.95

* Thread Joint Engagement

Do not use or test the products in this catalog with compressed air or other gases.

Tees

Chemtrol
Fig. No.

5111 Socket Tee (S x S x S)

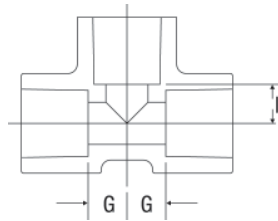

Nominal Size	Universal Part No.	Ctn. Qty.	Approx. Lbs./Ea.	Dim. G	Dim. G	Dim. I
1/4	1801-002	5	0.05	0.33	0.33	0.33
1/2	1801-005	25	0.16	0.52	0.52	0.52
3/4	1801-007	15	0.26	0.68	0.68	0.68
1	1801-010	20	0.39	0.74	0.74	0.74
1 1/4	1801-012	10	0.58	0.91	0.91	0.91
1 1/2	1801-015	10	0.78	1.05	1.05	1.05
2	1801-020	10	1.13	1.26	1.26	1.26
2 1/2	1801-025	5	1.72	1.52	1.52	1.52
3	1801-030	5	2.51	1.82	1.82	1.82
4	1801-040	5	4.41	2.33	2.33	2.33
6	1801-060	4	11.11	3.48	3.48	3.48
8*	1801-080	1	22.28	4.53	4.53	4.53
10	1801-100	1	38.52	5.72	5.72	5.72
12	1801-120	1	63.55	6.85	6.85	6.85

* Consult chart on page 41 of this catalog for special rating information.

5111R Reducing Socket Tee (S x S x S)

Nominal Size	Universal Part No.	Ctn. Qty.	Approx. Lbs./Ea.	Dim. G	Dim. G	Dim. I
3/4 x 3/4 x 1/2	1801-101	10	0.19	0.51	0.51	0.62
1 x 1 x 1/2	1801-130	10	0.26	0.52	0.52	0.73
1 x 1 x 3/4	1801-131	10	0.28	0.62	0.62	0.73
1 1/2 x 1 1/2 x 3/4	1801-210	10	0.51	0.66	0.66	1.04
1 1/2 x 1 1/2 x 1	1801-211	10	0.56	0.76	0.76	1.03
2 x 2 x 1/2	1801-247	5	0.65	0.60	0.60	1.29
2 x 2 x 3/4	1801-248	5	0.70	0.70	0.70	1.29
2 x 2 x 1	1801-249	5	0.75	0.80	0.80	1.29
2 x 2 x 1 1/2	1801-251	5	0.89	1.07	1.07	1.29
3 x 3 x 2	1801-338	5	1.92	1.36	1.36	1.84
4 x 4 x 2	1801-420	5	3.02	1.39	1.39	2.34
4 x 4 x 3	1801-422	5	3.62	1.87	1.87	2.34
6 x 6 x 4	1801-532	4	7.69	2.56	2.56	3.52

Other Reducing Tees are produced by solvent cementing Reducer Bushings with Socket Tees. They may be ordered as factory fabrications or may be assembled in the field.

Chemtrol
Fig. No.

5112 Socket x Thread Tee (S x S x FPT)

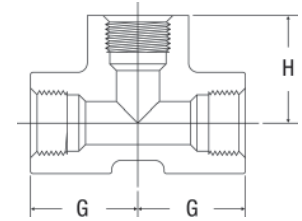

Nominal Size	Universal Part No.	Ctn. Qty.	Approx. Lbs./Ea.	Dim. G	Dim. G	Dim. H
1/2	1802-005	10	0.17	0.52	0.52	1.41
3/4	1802-007	10	0.28	0.68	0.68	1.70
1	1802-010	10	0.43	0.74	0.74	1.88
1 1/4	1802-012	10	0.62	0.91	0.91	2.17
1 1/2	1802-015	10	0.88	1.05	1.05	2.44
2	1802-020	10	1.23	1.26	1.26	2.77

5112-3-3 Thread Tee (FPT x FPT x FPT)

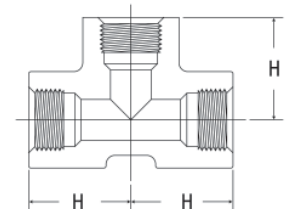

Nominal Size	Universal Part No.	Ctn. Qty.	Approx. Lbs./Ea.	Dim. H
1/4	1805-002	5	0.06	0.97
1/2	1805-005	10	0.17	1.41
3/4	1805-007	15	0.28	1.70
1	1805-010	10	0.43	1.88
1 1/4	1805-012	5	0.62	2.17
1 1/2	1805-015	5	0.88	2.44
2	1805-020	5	1.23	2.77
2 1/2	1805-025	5	1.91	3.30
3	1805-030	5	2.48	3.73
4	1805-040	5	4.88	4.61

For complete technical information and more, refer to our website at www.chemtrol.com.

Elbows

Chemtrol
Fig. No.

5107 Socket 90° ELL (S x S)

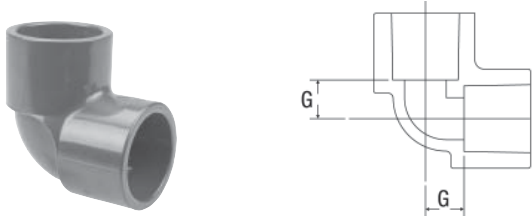

Nominal Size	Universal Part No.	Ctn. Qty.	Approx. Lbs./Ea.	Dim. G
1/4	1806-002	5	0.03	0.33
1/2	1806-005	20	0.12	0.52
3/4	1806-007	20	0.18	0.68
1	1806-010	15	0.27	0.74
1 1/4	1806-012	10	0.41	0.91
1 1/2	1806-015	10	0.54	1.05
2	1806-020	10	0.81	1.26
2 1/2	1806-025	5	1.23	1.52
3	1806-030	5	1.98	1.82
4	1806-040	5	3.44	2.33
6	1806-060	4	8.38	3.48
8*	1806-080	2	16.67	4.53
10	1806-100	1	30.14	5.72
12	1806-120	1	47.77	6.85

* Consult chart on page 41 of this catalog for special rating information.

5107-3 Socket x Thread 90° ELL (S x FPT)

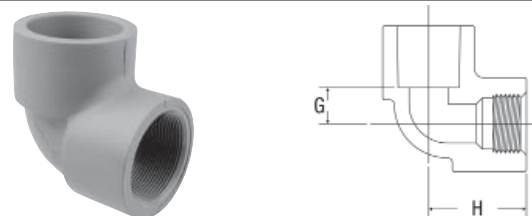

Nominal Size	Universal Part No.	Ctn. Qty.	Approx. Lbs./Ea.	Dim. G	Dim. H
1/2	1807-005	10	0.13	0.52	1.41
3/4	1807-007	10	0.19	0.68	1.70
1	1807-010	10	0.30	0.74	1.88
1 1/4	1807-012	10	0.45	0.91	2.17
1 1/2	1807-015	10	0.59	1.05	2.44
2	1807-020	10	0.86	1.26	2.77

Chemtrol
Fig. No.

5107-3-3 Thread 90° ELL (FPT x FPT)

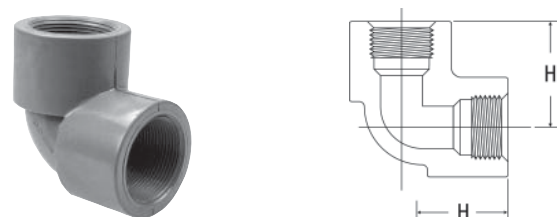

Nominal Size	Universal Part No.	Ctn. Qty.	Approx. Lbs./Ea.	Dim. H
1/4	1808-002	5	0.03	0.97
1/2	1808-005	10	0.13	1.41
3/4	1808-007	25	0.19	1.70
1	1808-010	15	0.30	1.88
1 1/4	1808-012	5	0.45	2.17
1 1/2	1808-015	5	0.59	2.44
2	1808-020	5	0.86	2.77
2 1/2	1808-025	5	1.34	3.30
3	1808-030	5	2.14	3.73
4	1808-040	5	3.85	4.61

5106 Socket 45° ELL (S x S)

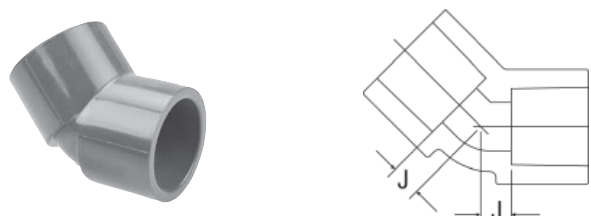

Nominal Size	Universal Part No.	Ctn. Qty.	Approx. Lbs./Ea.	Dim. J
1/4	1817-002	5	0.03	0.18
1/2	1817-005	20	0.10	0.26
3/4	1817-007	10	0.15	0.33
1	1817-010	15	0.24	0.37
1 1/4	1817-012	10	0.34	0.42
1 1/2	1817-015	10	0.47	0.46
2	1817-020	10	0.67	0.60
2 1/2	1817-025	5	0.99	0.67
3	1817-030	6	1.48	0.77
4	1817-040	6	2.62	1.01
6	1817-060	4	6.62	1.74
8*	1817-080	2	13.63	2.20
10	1817-100	1	21.44	2.59
12	1817-120	1	35.59	3.05

* Consult chart on page 41 of this catalog for special rating information.

Product Guide — Corzan® CPVC Schedule 80

Chemtrol
Fig. No.

5106-3-3 Thread 45° ELL (FPT x FPT)

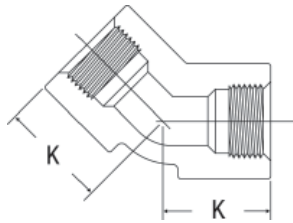

Nominal Size	Universal Part No.	Ctn. Qty.	Approx. Lbs./Ea.	Dim. K
1/4	1819-002	5	0.04	0.82
1/2	1819-005	10	0.11	1.15
3/4	1819-007	10	0.16	1.34
1	1819-010	15	0.27	1.51
1 1/4	1819-012	5	0.38	1.69
1 1/2	1819-015	5	0.52	1.85
2	1819-020	5	0.76	2.12
2 1/2	1819-025	5	1.09	2.45
3	1819-030	6	1.70	2.68
4	1819-040	6	3.06	3.29

Couplings

5101 Socket Couplings (S x S)

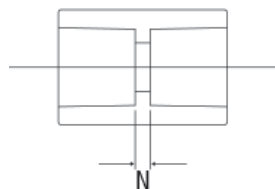

Nominal Size	Universal Part No.	Ctn. Qty.	Approx. Lbs./Ea.	Dim. N
1/4	1829-002	5	0.06	0.12
1/2	1829-005	25	0.10	0.24
3/4	1829-007	15	0.14	0.24
1	1829-010	20	0.22	0.24
1 1/4	1829-012	10	0.31	0.24
1 1/2	1829-015	10	0.40	0.24
2	1829-020	10	0.57	0.24
2 1/2	1829-025	55	0.73	0.19
3	1829-030	5	1.12	0.18
4	1829-040	5	1.94	0.18
6	1829-060	4	4.01	0.23
8*	1829-080	2	9.23	0.22
10	1829-100	1	14.62	0.35
12	1829-120	1	25.26	0.46

Chemtrol
Fig. No.

5101 Reducing Socket Coupling (S x S)

Nominal Size	Universal Part No.	Ctn. Qty.	Approx. Lbs./Ea.	Dim. N
3/4 x 1/2	1829-101	5	0.13	0.43
1 x 1/2	1829-130	5	0.20	0.66
1 x 3/4	1829-131	5	0.20	0.54
1 1/4 x 3/4	1829-167	5	0.28	0.71
1 1/4 x 1	1829-168	5	0.30	0.59
1 1/2 x 3/4	1829-210	5	0.35	0.75
1 1/2 x 1	1829-211	5	0.36	0.62
1 1/2 x 1 1/4	1829-212	5	0.38	0.50
2 x 1	1829-249	5	0.50	0.73
2 x 1 1/2	1829-251	5	0.54	0.48
3 x 2	1829-338	5	1.08	1.23
4 x 2	1829-420	5	1.73	1.57
4 x 3	1829-422	5	1.98	1.18

Other Reducing Couplings are produced by solvent cementing Reducer Bushings into Socket Couplings. They may be ordered as factory fabrications or may be assembled in the field.

5101-3-3 Thread Coupling (FPT x FPT)

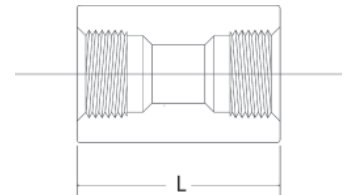

Nominal Size	Universal Part No.	Ctn. Qty.	Approx. Lbs./Ea.	Dim. L
1/4	1830-002	5	0.07	1.40
1/2	1830-005	25	0.08	2.02
3/4	1830-007	25	0.13	2.27
1	1830-010	15	0.21	2.52
1 1/4	1830-012	5	0.31	2.77
1 1/2	1830-015	5	0.46	3.02
2	1830-020	5	0.64	3.27
2 1/2	1830-025	5	0.89	3.75
3	1830-030	5	1.30	3.99
4	1830-040	5	2.31	4.74

5101-3-3 Reducing Thread Coupling (FPT x FPT)

Nominal Size	Universal Part No.	Ctn. Qty.	Approx. Lbs./Ea.	Dim. L
3/4 x 1/2	1830-101	5	0.15	2.33
1 x 1/2	1830-130	5	0.22	2.69
1 x 3/4	1830-131	5	0.23	2.69
1 1/4 x 3/4	1830-167	5	0.32	2.99
1 1/4 x 1	1830-168	5	0.34	2.99
1 1/2 x 3/4	1830-210	5	0.39	3.15
1 1/2 x 1	1830-211	5	0.40	3.15
1 1/2 x 1 1/4	1830-212	5	0.42	3.15
2 x 1	1830-249	5	0.53	3.39
2 x 1 1/2	1830-251	5	0.58	3.39

Other Reducing Couplings are produced by solvent cementing Reducer Bushings into Socket Couplings. They may be ordered as factory fabrications or may be assembled in the field.

Corzan® is a registered trademark of The Lubrizol Corporation.

Do not use or test the products in this catalog with compressed air or other gases.

Adapters

Chemtrol
Fig. No.

5103 Female Adapter Coupling (S x FPT)

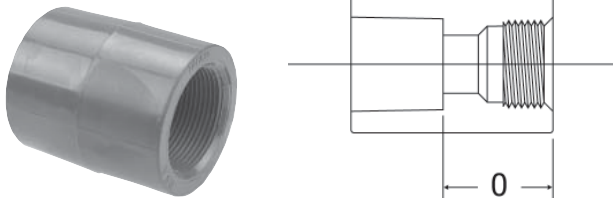

Nominal Size	Universal Part No.	Ctn. Qty.	Approx. Lbs./Ea.	Dim. O
1/4	1835-002	5	0.06	0.76
1/2	1835-005	15	0.10	1.13
3/4	1835-007	10	0.15	1.26
1	1835-010	10	0.23	1.38
1 1/4	1835-012	5	0.34	1.51
1 1/2	1835-015	5	0.43	1.63
2	1835-020	5	0.60	1.76
2 1/2	1835-025	5	0.82	1.97
3	1835-030	5	1.27	2.08
4	1835-040	5	1.13	2.46

5104 Male Adapter (S x MPT)



Nominal Size	Universal Part No.	Ctn. Qty.	Approx. Lbs./Ea.	Dim. O _M
1/2	1836-005	25	0.04	0.94
3/4	1836-007	25	0.06	0.96
1	1836-010	25	0.10	1.14
1 1/4	1836-012	10	0.14	1.11
1 1/2	1836-015	10	0.19	1.11
2	1836-020	10	0.27	1.19
2 1/2	1836-025	5	0.56	1.88
3	1836-030	5	0.79	1.97
4	1836-040	5	1.56	2.08

Bushings

Design Styles

The design style of most bushings is to have a solid wall between the inside and outside connections. Some of the multistep reductions with exceedingly thick cross-sections are not solid. This design style achieves structural support with a web of ribs attaching the inner and outer connection walls, with the open area toward the exterior bushing face. The styles are denoted by W and S for webbed and solid designs respectively.

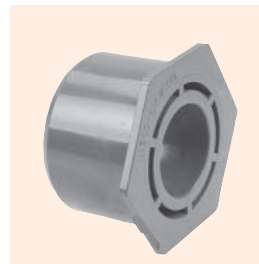

Webbed design

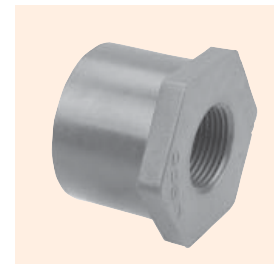

Solid design

Chemtrol
Fig. No.

5118 Flush Socket Reducer Bushing (SPG x S)



Nominal Size	Universal Part No.	Ctn. Qty.	Approx. Lbs./Ea.	Design Style	Dim. L _i	Dim. N _N
1/2 x 1/4	1837-072	25	0.04	S	1.17	0.53
3/4 x 1/2	1837-101	25	0.06	S	1.15	0.26
1 x 1/2	1837-130	25	0.07	S	1.28	0.39
1 x 3/4	1837-131	25	0.06	S	1.28	0.26
1 1/4 x 1/2	1837-166	10	0.11	S	1.41	0.52
1 1/4 x 3/4	1837-167	10	0.09	S	1.41	0.39
1 1/4 x 1	1837-168	10	0.07	S	1.41	0.27
1 1/2 x 1/2	1837-209	10	0.13	W	1.53	0.64
1 1/2 x 3/4	1837-210	10	0.11	S	1.53	0.51
1 1/2 x 1	1837-211	10	0.09	S	1.53	0.39
1 1/2 x 1 1/4	1837-212	10	0.07	S	1.53	0.26
2 x 1/2	1837-247	10	0.27	W	1.66	0.77
2 x 3/4	1837-248	10	0.27	W	1.66	0.64
2 x 1	1837-249	10	0.27	W	1.66	0.52
2 x 1 1/4	1837-250	5	0.23	S	1.66	0.39
2 x 1 1/2	1837-250	10	0.21	S	1.66	0.27
2 1/2 x 2	1837-292	5	0.26	S	1.93	0.42
3 x 1 1/2	1837-337	5	0.75	W	2.41	1.02
3 x 2	1837-338	5	0.70	S	2.41	0.90
3 x 2 1/2	1837-339	5	0.49	S	2.41	0.63

Chemtrol
Fig. No.

5118 Flush Socket Reducer Bushing (SPG x S) (cont.)

Nominal Size	Universal Part No.	Ctn. Qty.	Approx. Lbs./Ea.	Design Style	Dim. L _L	Dim. N _N
4 x 2	1837-420	5	1.25	W	2.80	1.29
4 x 3	1837-422	5	1.01	S	2.80	0.90
6 x 4	1837-532	5	2.97	S	3.05	0.77
8 x 6	1837-585	2	6.00	S	4.58	1.55
10 x 6	1837-422	1	10.80	W	5.57	2.54
10 x 8	1837-626	1	9.36	S	5.57	1.07
12 x 8	1837-668	1	18.79	W	6.57	2.07
12 x 10	1837-670	1	12.78	S	6.57	1.07

Other size reductions are produced by solvent cementing appropriate Reducer Bushings together. They may be ordered as factory fabrications or may be assembled in the field.

5118-3 Flush Spigot x Thread Reducer Bushing (SPG x FPT)

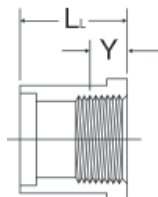

Nominal Size	Universal Part No.	Ctn. Qty.	Approx. Lbs./Ea.	Design Style	Dim. L _L	Dim. Y*
1/2 x 1/4	1838-072	25	0.03	S	1.17	0.31
3/4 x 1/2	1838-101	25	0.03	S	1.29	0.43
1 x 1/2	1838-130	25	0.07	S	1.56	0.43
1 x 3/4	1838-131	25	0.06	S	1.56	0.45
1 1/4 x 1/2	1838-166	10	0.15	S	1.66	0.43
1 1/4 x 3/4	1838-167	10	0.13	S	1.66	0.45
1 1/4 x 1	1838-168	10	0.11	S	1.66	0.53
1 1/2 x 1/2	1838-209	10	0.23	S	1.77	0.43
1 1/2 x 3/4	1838-210	10	0.21	S	1.77	0.45
1 1/2 x 1	1838-211	10	0.19	S	1.77	0.53
1 1/2 x 1 1/4	1838-212	10	0.13	S	1.77	0.55
2 x 1/2	1838-247	10	0.36	S	1.91	0.43
2 x 3/4	1838-248	10	0.34	S	1.91	0.45
2 x 1	1838-249	10	0.32	S	1.91	0.53
2 x 1 1/4	1838-250	10	0.26	S	1.91	0.55
2 x 1 1/2	1838-251	10	0.21	S	1.91	0.55
2 1/2 x 2	1838-292	5	0.32	S	2.17	0.57
3 x 2	1838-338	5	0.73	S	2.41	0.57
3 x 2 1/2	1838-339	5	0.57	S	2.41	0.87
4 x 2	1838-420	5	1.30	W	2.80	0.57
4 x 3	1838-422	5	1.06	S	2.80	0.95

Other size reductions are produced by solvent cementing appropriate Reducer Bushings together. They may be ordered as factory fabrications or may be assembled in the field.

*Typical male component engagement, hand tight (L₁ in ANSI B1.20.1 thread spec.) plus 1 1/2 turns.

Chemtrol
Fig. No.

5118-3-4 Flush Thread Reducer Bushing (MPT x FPT)

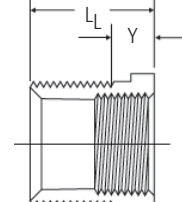

Nominal Size	Universal Part No.	Ctn. Qty.	Approx. Lbs./Ea.	Design Style	Dim. L _L	Dim. Y*
1/2 x 1/4	1839-072	25	0.02	S	0.95	0.25
3/4 x 1/2	1839-101	25	0.03	S	0.95	0.25
1 x 1/2	1839-130	25	0.06	S	1.24	0.38
1 x 3/4	1839-131	25	0.05	S	1.24	0.38
1 1/4 x 1/2	1839-166	10	0.13	S	1.27	0.38
1 1/4 x 3/4	1839-167	10	0.11	S	1.27	0.38
1 1/4 x 1	1839-168	10	0.09	S	1.27	0.38
1 1/2 x 1/2	1839-209	10	0.20	S	1.28	0.38
1 1/2 x 3/4	1839-210	10	0.18	S	1.28	0.38
1 1/2 x 1	1839-211	10	0.17	S	1.28	0.38
1 1/2 x 1 1/4	1839-212	10	0.11	S	1.28	0.38
2 x 1/2	1839-247	5	0.30	S	1.32	0.38
2 x 3/4	1839-248	5	0.28	S	1.32	0.38
2 x 1	1839-249	5	0.28	S	1.32	0.38
2 x 1 1/4	1839-250	5	0.27	S	1.32	0.38
2 x 1 1/2	1839-251	5	0.15	S	1.32	0.38
2 1/2 x 2	1839-292	5	0.24	S	2.18	0.57
3 x 1 1/2	1839-337	5	0.64	W	2.42	0.55
3 x 2	1839-338	5	0.59	S	2.42	0.57
3 x 2 1/2	1839-339	5	0.54	S	2.42	0.87
4 x 2	1839-420	5	1.01	W	2.81	0.57
4 x 3	1839-422	5	0.95	S	2.81	0.95

Other size reductions are produced by solvent cementing appropriate Reducer Bushings together. They may be ordered as factory fabrications or may be assembled in the field.

*Typical male component engagement, hand tight (L₁ in ANSI B1.20.1 thread spec.) plus 1 1/2 turns.

Caps

Chemtrol
Fig. No.

5117 Socket Cap* (S)

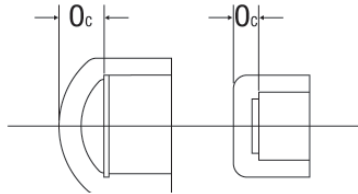

Nominal Size	Universal Part No.	Ctn. Qty.	Approx. Lbs./Ea.	Dim. O _c
1/4	1847-002	5	0.03	0.25
1/2	1847-005	10	0.06	0.39
3/4	1847-007	10	0.09	0.36
1	1847-010	5	0.14	0.41
1 1/4	1847-012	5	0.22	0.39
1 1/2	1847-015	5	0.28	0.41
2	1847-020	5	0.40	0.41
2 1/2	1847-025	5	0.62	1.56
3	1847-030	5	1.00	1.28
4	1847-040	5	1.61	1.57
6	1847-060	5	4.06	2.11

*Sizes 2" and smaller are flat; 2 1/2" and larger are domed.

5117-3 Thread Cap* (FPT)

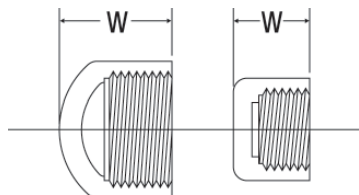

Nominal Size	Universal Part No.	Ctn. Qty.	Approx. Lbs./Ea.	Dim. W
1/4	1848-002	5	0.02	0.89
1/2	1848-005	5	0.07	1.28
3/4	1848-007	5	0.10	1.38
1	1848-010	5	0.16	1.55
1 1/4	1848-012	5	0.25	1.66
1 1/2	1848-015	5	0.31	1.80
2	1848-020	5	0.46	1.92
2 1/2	1848-025	5	0.68	2.34
3	1848-030	5	1.03	3.18
4	1848-040	5	1.85	3.85

*Sizes 2" and smaller are flat; 2 1/2" and larger are domed.

Plugs

Chemtrol
Fig. No.

5116-4 Thread Plug (MPT)

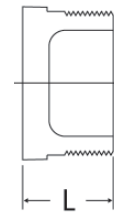

Nominal Size	Universal Part No.	Ctn. Qty.	Approx. Lbs./Ea.	Dim. L
1/4	1850-002	5	0.01	0.85
1/2	1850-005	10	0.03	1.04
3/4	1850-007	10	0.04	1.10
1	1850-010	5	0.07	1.25
1 1/4	1850-012	5	0.11	1.66
1 1/2	1850-015	5	0.16	1.77
2	1850-020	5	0.20	1.91
2 1/2	1850-025	5	0.32	2.17
3	1850-030	5	0.56	2.41
4	1850-040	5	0.95	2.80

Class 150 Flanges

For flange dimensions that comply with ANSI B16.5, 150 lb., steel flanges, see page 39.

5151-W Socket Flange (S), One-Piece (Webbed Design)

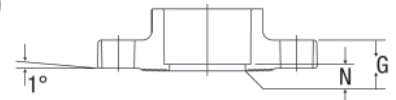

Nominal Size	Universal Part No.	Ctn. Qty.	Approx. Lbs./Ea.	Dim. G	Dim. N
2	1851-020	10	0.89	0.91	0.26
3	1851-030	10	1.80	1.13	0.28
4	1851-040	10	2.72	1.24	0.31
6	1851-060	5	4.14	1.36	0.31

Reducing Flanges are produced by solvent cementing Reducer Bushings into Socket Flanges. They may be ordered as factory fabrications or may be assembled in the field.

Note: One-piece webbed flanges have oblong bolt holes which permit mating with ANSI B16.5, 150 lb.; BS 1560, class 150; ISO 2084, PN10; and DIN 2532, PN10.

*Chemtrol has seminars available to educate in the design and installation of thermoplastic piping systems. For more information, call our customer service department at **800.343.5455**.*

Chemtrol
Fig. No.

5151-H Socket Flange (S), One-Piece (Solid)

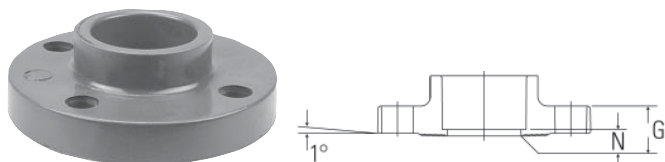

Nominal Size	Universal Part No.	Ctn. Qty.	Approx. Lbs./Ea.	Dim. G	Dim. N
1/2	1851-H05	10	0.22	0.54	0.20
3/4	1851-H07	15	0.31	0.61	0.17
1	1851-H10	10	0.45	0.68	0.18
1 1/4	1851-H12	5	0.59	0.72	0.20
1 1/2	1851-H15	10	0.73	0.82	0.21
2	1851-H20	10	1.12	0.91	0.26
2 1/2	1851-H25	5	1.77	1.02	0.20
3	1851-H30	10	2.27	1.13	0.28
4	1851-H40	10	3.17	1.24	0.31
6	1851-H60	5	5.04	1.36	0.31
8	1851-H80	2	9.35	1.52	0.35

Reducing Flanges are produced by solvent cementing Reducer Bushings into Socket Flanges. They may be ordered as factory fabrications or may be assembled in the field.

5151-W-3 Thread Flange (FPT), One-Piece (Webbed Design)

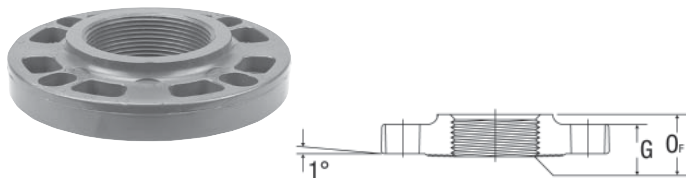

Nominal Size	Universal Part No.	Ctn. Qty.	Approx. Lbs./Ea.	Dim. G	Dim. O _F
2	1852-020	5	0.88	0.91	1.17
3	1852-030	5	1.73	1.13	1.55
4	1852-040	5	2.53	1.24	1.67

Reducing Flanges are produced by solvent cementing Reducer Bushings into Socket Flanges. They may be ordered as factory fabrications or may be assembled in the field.

Note: One-piece webbed flanges have oblong bolt holes which permit mating with ANSI B16.5, 150 lb.; BS 1560, class 150; ISO 2084, PN10; and DIN 2532, PN10.

Chemtrol
Fig. No.

5151-H-3 Thread Flange (FPT), One-Piece (Solid)

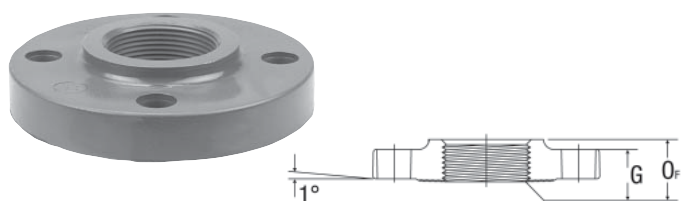

Nominal Size	Universal Part No.	Ctn. Qty.	Approx. Lbs./Ea.	Dim. G	Dim. O _F
1/2	1852-H05	10	0.23	0.54	0.88
3/4	1852-H07	10	0.34	0.61	0.91
1	1852-H10	10	0.44	0.68	1.08
1 1/4	1852-H12	5	0.55	0.72	1.11
1 1/2	1852-H15	5	0.69	0.82	1.12
2	1852-H20	5	1.05	0.91	1.17
2 1/2	1852-H25	5	1.65	1.02	1.42
3	1852-H30	5	1.84	1.13	1.55
4	1852-H40	5	2.80	1.24	1.67

Reducing Flanges are produced by solvent cementing Reducer Bushings into Socket Flanges. They may be ordered as factory fabrications or may be assembled in the field.

5119-W Blind Flange, One-Piece (Webbed Design)

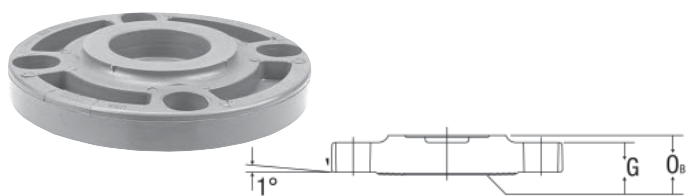

Nominal Size	Universal Part No.	Ctn. Qty.	Approx. Lbs./Ea.	Dim. G	Dim. O _B
2	1853-020	5	0.88	0.91	1.17
3	1853-030	5	1.98	1.13	1.39
4	1853-040	5	2.88	1.24	1.51
6	1853-060	5	5.07	1.36	1.60

Note: One-piece webbed flanges have oblong bolt holes which permit mating with ANSI B16.5, 150 lb.; BS 1560, class 150; ISO 2084, PN10; and DIN 2532, PN10.

*For questions concerning thermoplastic piping systems, please call or fax: **888.446.4226 (ph)**, **888.336.4226 (fx)**.*

Chemtrol
Fig. No.

5119-H Blind Flange, One-Piece (Solid)

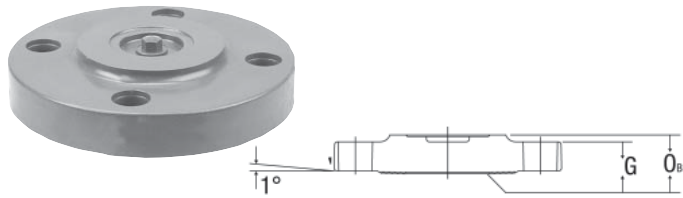

Nominal Size	Universal Part No.	Ctn. Qty.	Approx. Lbs./Ea.	Dim. G	Dim. O _B
1/2	1853-H05	5	0.28	0.54	0.76
3/4	1853-H07	5	0.34	0.61	0.83
1	1853-H10	5	0.48	0.68	0.88
1 1/4	1853-H12	5	0.63	0.72	0.95
1 1/2	1853-H15	5	0.81	0.82	1.04
2	1853-H20	5	1.24	0.91	1.12
2 1/2	1853-H25	5	2.03	1.02	1.22
3	1853-H30	5	2.65	1.13	1.39
4	1853-H40	5	3.94	1.24	1.57
6	1853-H60	5	6.93	1.36	1.60
8	1853-H80	2	11.23	1.51	1.77

5151-A Socket Flange (S), Van Stone

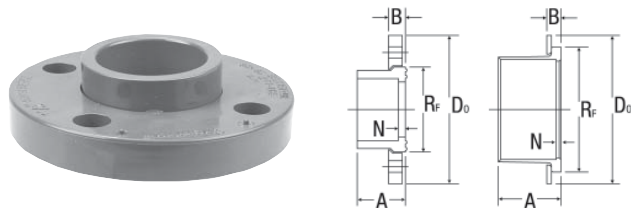

Nominal Size	Universal Part No.	Ctn. Qty.	Approx. Lbs./Ea.	Dim. A	Dim. B	Dim. D _O	Dim. R _F	Dim. N
1/2	1854-005	10	0.21	1.00	.50	3.49	1.48	0.11
3/4	1854-007	15	0.26	1.12	.50	3.86	1.75	0.11
1	1854-010	10	0.41	1.25	.56	4.24	2.04	0.11
1 1/4	1854-012	5	0.44	1.37	.63	4.61	2.50	0.11
1 1/2	1854-015	10	0.59	1.50	.69	4.99	2.78	0.11
2	1854-020	10	1.00	1.62	.75	5.98	3.41	0.11
2 1/2	1854-025	5	1.49	1.93	.94	6.98	4.11	0.15
3	1854-030	10	1.87	2.40	1.04	7.48	4.80	0.50
4	1854-040	10	2.84	2.75	1.16	8.95	6.17	0.48
6	1854-060	5	4.88	3.55	1.28	10.97	7.95	0.53
8	1854-080	2	13.13	5.00	1.42	13.46	10.42	0.50

Van Stone Flange Assembly List

Item	Description	Material
1	Connector Hub	CPVC
3	Flange Ring	CPVC

Chemtrol
Fig. No.

NR 51 Flange Gaskets, for Class 150 Flanges

Note: These gaskets are 1/8" thick, full face polychloroprene (CR), 70 durometer.



Nominal Size	Part No.	Approx. Lbs./Ea.
1/2	↑ Use Figure No. & Nom. Size ↓	0.11
3/4		0.12
1		0.13
1 1/4		0.14
1 1/2		0.15
2		0.20
2 1/2		0.25
3		0.28
4		0.30
6		0.40
8	0.50	

Flanged Fittings*— Fabricated from Molded Components

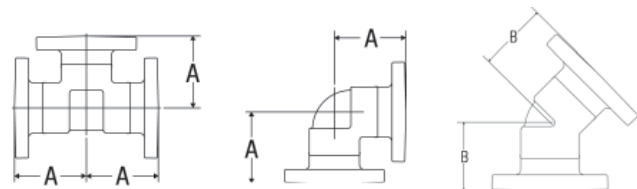

Nominal Size	Fig. No. 4511-12 Flanged Tee		Fig. No. 4507-12 Flanged 90° ELL		Fig. No. 4506-12 Flanged 45° ELL	
	Approx. Lbs./Ea.	Dim. A	Approx. Lbs./Ea.	Dim. A	Approx. Lbs./Ea.	Dim. B
1	1.98	3 3/32	1.34	3 3/32	1.31	2 23/32
1 1/4	2.75	3 19/32	1.86	3 19/32	1.79	3 3/32
1 1/2	3.49	3 31/32	2.35	3 31/32	2.27	3 13/32
2	5.23	4 15/32	3.54	4 15/32	3.40	3 27/32
2 1/2	8.38	5 7/32	5.67	5 7/32	5.43	4 13/32
3	11.32	5 13/32	7.85	5 13/32	7.35	4 25/32
4	17.36	7 3/32	12.07	7 3/32	11.29	5 25/32
6	32.74	9 25/32	24.50	9 25/32	22.75	8 1/2
8	—	—	—	—	—	—

* Flanged fittings are produced by solvent cementing socket flanges to socket fittings with short plain end pipe nipples. They may be ordered as factory fabrications or may be assembled in the field.

*Chemtrol sells its products through a select group of highly trained distributors. Please call **800.343.5455** for a listing of distributors in your area.*

Unions

Chemtrol
Fig. No.

5133 FKM/5133E (EPDM) Socket Union (S x S)

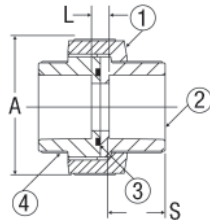
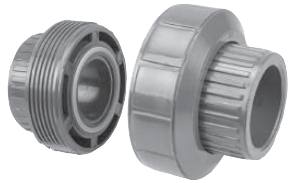

Nominal Size	FKM Part No.	EPDM Part No.	Ctn. Qty.	Approx. Lbs./Ea.	Dim. A	Dim. L	Dim. S*
1/4	1897-002	1897E002	5	0.10	1.70	0.41	0.64
1/2	1897-005	1897E005	10	0.17	1.99	0.43	0.89
3/4	1897-007	1897E007	10	0.30	2.43	0.44	1.02
1	1897-010	1897E010	5	0.43	2.82	0.43	1.14
1 1/4	1897-012	1897E012	5	0.94	4.07	0.79	1.27
1 1/2	1897-015	1897E015	5	1.01	4.07	0.81	1.39
2	1897-020	1897E020	5	1.98	5.24	0.80	1.52
3	1897-030	1897E030	5	3.77	7.15	0.94	1.91

Socket x Thread is available on request in all sizes except 2 1/2". The 2 1/2" Socket Union is available as a fabrication from the 3" size Bushed down.

* Socket Depth

5133-3-3 FKM/5133E-3-3 (EPDM) Threaded Union (FPT x FPT)

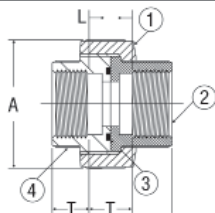

Nominal Size	FKM Part No.	EPDM Part No.	Ctn. Qty.	Approx. Lbs./Ea.	Dim. A	Dim. L	Dim. S*
1/4	1898-002	1898E002	5	0.10	1.69	1.07	0.31
1/2	1898-005	1898E005	5	0.17	1.99	1.30	0.43
3/4	1898-007	1898E007	5	0.30	2.43	1.37	0.45
1	1898-010	1898E010	5	0.44	2.82	1.51	0.53
1 1/4	1898-012	1898E012	5	0.97	4.07	2.01	0.55
1 1/2	1898-015	1898E015	5	1.00	4.07	2.16	0.57
2	1898-020	1898E020	5	1.98	5.24	2.36	0.57
3	1898-030	1898E030	5	3.99	7.15	2.685	0.95

Socket x Thread is available on request in all sizes except 2 1/2". The 2 1/2" Socket Union is available as a fabrication from the 3" size Bushed down.

* Thread Joint Engagement

Chemtrol
Fig. No.

5133-3 FKM / 5133E-3 (EPDM) Female Adapter Union (S x FPT)

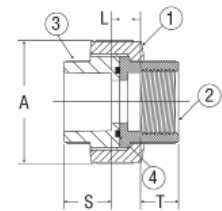

Nominal Size	FKM Part No.	EPDM Part No.	Ctn. Qty.	Approx. Lbs./Ea.	Dim. A	Dim. L	Dim. S*	Dim. T†
1/2	1899-005	1899E005	10/5	0.163	1.99	0.84	0.89	0.43
3/4	1899-007	1899E007	10	0.282	2.43	0.81	1.02	0.45
1	1899-010	1899E010	10	0.411	2.82	0.90	1.14	0.53
1 1/4	1899-012	1899E012	10	0.943	4.07	1.29	1.27	0.55
1 1/2	1899-015	1899E015	10	0.967	4.07	1.32	1.39	0.55
2	1899-020	1899E020	5	1.880	5.24	1.41	1.52	0.57
3	1899-030	1899E030	5	4.100	7.15	1.90	1.91	0.95

The 2 1/2" Socket x Thread Union is available as a fabrication from the 3" size Bushed down.

* Socket Depth

† Thread Joint Engagement

Transition Unions

Materials of Construction

Item	Description	Material
1	Union Nut	CPVC
2	End Connector	Brass/SS
3	O-Ring	FKM/EPDM
4	Union Tailpiece	CPVC

- TCBR-3 Brass End Connector (FPT)
- TCBR-4 Brass End Connector (MPT)
- TCSS-3 Stainless Steel End Connector (FPT)
- TCSS-4 Stainless Steel End Connector (MPT)

Refer to page 13 for purchase and assembly instructions of Transition Unions and for part number, size, carton quantity, weights, and dimensions of Metal End Connectors.

Nipples

Chemtrol
Fig. No.

5131 Plain End Pipe Nipple (SPG x SPG)

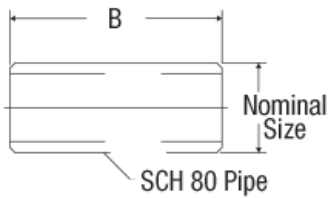

Used for solvent cementing
joining any
fittings face-

Nominal Size	Part Number	Ctn. Qty.	Approx. Lbs./Ea.	Dim. B
1/2	Use Figure No. & Nom. Size	12	0.04	1.75
3/4		12	0.05	2.00
1		12	0.09	2.25
1 1/4		12	0.14	2.50
1 1/2		12	0.19	2.75
2		12	0.27	3.00
2 1/2		12	0.48	3.50
3		12	0.69	3.75
4		12	1.21	4.25
6		6	3.08	6.00
8	2	6.70	8.18	

5129 Thread Pipe Nipple (MPT x MPT)

Nominal Size	Ctn. Qty.	Length – Close			Length – Short		
		Universal Part No.	Approx. Lbs./Ea.	Dim. A	Universal Part No.	Approx. Lbs./Ea.	Dim. A
1/4	25	1861-037	0.01	0.88	1861-038	0.01	1.50
1/2	25	1861-077	0.02	1.13	1861-078	0.02	1.50
3/4	25	1861-104	0.03	1.38	1861-105	0.04	2.00
1	25	1861-133	0.04	1.50	1861-134	0.06	2.00
1 1/4	10	1861-170	0.06	1.63	1861-171	0.10	2.50
1 1/2	10	1861-213	0.08	1.75	1861-214	0.11	2.50
2	10	1861-251	0.14	2.00	1861-252	0.18	2.50
2 1/2	5	1861-292	0.27	2.50	1861-293	0.36	3.00
3	5	1861-338	0.38	2.63	1861-340	0.45	3.00
4	5	1861-422	0.62	2.88	1861-423	0.84	4.00

Nom. Size	Ctn. Qty.	Length – 2"		Length – 3"		Length – 4"	
		Universal Part No.	Approx. Lbs./Ea.	Universal Part No.	Approx. Lbs./Ea.	Universal Part No.	Approx. Lbs./Ea.
1/4	25	1861-039	0.02	1861-041	0.02	1861-042	0.03
1/2	25	1861-079	0.03	1861-081	0.05	1861-082	0.07
3/4	25	–	–	1861-106	0.06	1861-107	0.09
1	25	–	–	1861-135	0.09	1861-136	0.13
1	10	–	–	1861-172	0.14	1861-173	0.18
1 1/2	10	–	–	1861-215	0.17	1861-216	0.27
2	10	–	–	1861-253	0.24	1861-254	0.36
2 1/2	5	–	–	See Short	–	1861-295	0.55
3	5	–	–	See Short	–	1861-341	0.73
4	5	–	–	See Short	–	See Short	–

Chemtrol
Fig. No.

5129 Thread Pipe Nipple (MPT x MPT) (cont.)

Nominal Size	Ctn. Qty.	Length – 5"		Length – 6"	
		Universal Part No.	Approx. Lbs./Ea.	Universal Part No.	Approx. Lbs./Ea.
1/4	25	1861-043	0.05	1861-044	0.06
1/2	25	1861-083	0.10	1861-084	0.12
3/4	25	1861-108	0.13	1861-109	0.16
1	25	1861-137	0.20	1861-138	0.24
1 1/4	10	1861-174	0.27	1861-175	0.33
1 1/2	10	1861-217	0.33	1861-218	0.40
2	10	1861-255	0.45	1861-256	0.54
2 1/2	5	1861-296	0.69	1861-297	0.82
3	5	1861-342	0.92	1861-343	1.10
4	5	1861-425	1.34	1861-426	1.61

Corzan® is a registered trademark of The Lubrizol Corporation.

Do not use or test the products in this catalog with compressed air or other gases.

Pipe

Chemtrol
Fig. No.

6100-80(1/2"-6")/6200-80(1/2"-4") Plain End Schedule 80 Pipe (20 ft. Lengths)

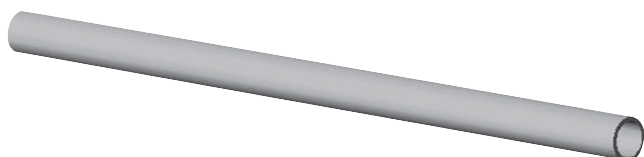

Pipe is ordered and specified with the Chemtrol figure number followed by the nominal size (e.g., 1 1/2" Schedule 80 PP Pipe – 6100 1 1/2"). Weights and dimensions for all pipe may be found on page 39 of this catalog.

Tees

6111/6211 Socket Tee (S x S x S)

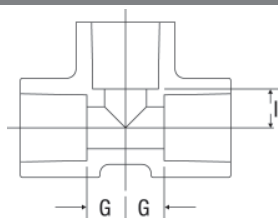

Nominal Size	Universal Part No. Black	Chem-Pure	Ctn. Qty.	Approx. Lbs./Ea.	Dim. G	Dim. I
1/2	2801-005	7801-005	10	0.09	0.53	0.53
3/4	2801-007	7801-007	10	0.14	0.70	0.70
1	2801-010	7801-010	10	0.19	0.76	0.76
1 1/2	2801-015	7801-015	10	0.43	1.06	1.06
2	2801-020	7801-020	10	1.69	1.25	1.25
3	2801-030	7801-030	5	1.43	1.83	1.83
4	2801-040	7801-040	5	2.41	2.32	2.32
6	2801-060	—	2	5.71	3.44	3.44

6112-3-3/6212-3-3 Thread* Tee (FPT x FPT x FPT)

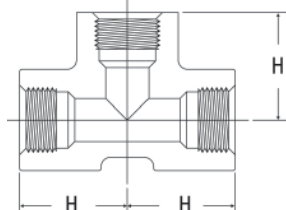

Nominal Size	Universal Part No. Black	Chem-Pure	Ctn. Qty.	Approx. Lbs./Ea.	Dim. H
1/2	2805-005	7805-005	10	0.10	1.38
3/4	2805-007	7805-007	10	0.16	1.67
1	2805-010	7805-010	10	0.24	1.86
1 1/4	2805-012	7805-012	10	0.35	2.14
1 1/2	2805-015	7805-015	10	0.46	2.41
2	2805-020	7805-020	10	0.67	2.73
3	2805-030	7805-030	5	1.54	3.67
4	2805-040	7805-040	5	1.97	4.54

* Recommended for intermittent service not exceeding 20 psi.

Elbows

Chemtrol
Fig. No.

6107/6207 Socket 90° ELL (S x S)

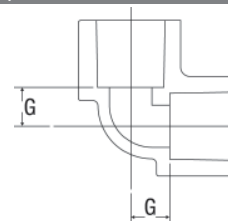

Nominal Size	Universal Part No. Black	Chem-Pure	Ctn. Qty.	Approx. Lbs./Ea.	Dim. G
1/2	2806-005	7806-005	10	0.06	0.53
3/4	2806-007	7806-007	10	0.08	0.70
1	2806-010	7806-010	10	0.15	0.76
1 1/2	2806-015	7806-015	10	0.32	1.06
2	2806-020	7806-020	10	0.49	1.25
3	2806-030	7806-030	5	1.14	1.83
4	2806-040	7806-040	5	1.93	2.32
6	2806-060	—	2	4.47	3.44

6107-3-3/6207-3-3 Thread* 90° ELL (FPT x FPT)

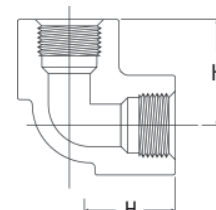

Nominal Size	Universal Part No. Black	Chem-Pure	Ctn. Qty.	Approx. Lbs./Ea.	Dim. H
1/2	2808-005	7808-005	10	0.07	1.38
3/4	2808-007	7808-007	10	0.11	1.67
1	2808-010	7808-010	10	0.16	1.86
1 1/4	2808-012	7808-012	10	0.25	2.14
1 1/2	2808-015	7808-015	10	0.33	2.41
2	2808-020	7808-020	10	0.49	2.73
3	2808-030	7808-030	5	1.12	3.67
4	2808-040	7808-040	5	2.02	4.54

*Recommended for intermittent service not exceeding 20 psi.

6107-12 Flanged 90° ELL

Flanged fitting center-to-face dimensions may be found on page 30. When ordering, specify the figure number and the nominal size (e.g., 2" Schedule 80 PP Flanged Tee – 6107-12 2").

*For questions concerning thermoplastic piping systems, please call or fax: **888.446.4226 (ph)**, **888.336.4226 (fx)**.*

Do not use or test the products in this catalog with compressed air or other gases.

Chemtrol
Fig. No.

6106/6206 Socket 45° ELL (S x S)

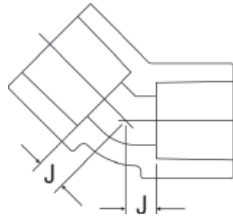

Nominal Size	Universal Part No.		Ctn. Qty.	Approx. Lbs./Ea.	Dim. J
	Black	Chem-Pure			
1/2	2817-005	7817-005	10	0.06	0.28
3/4	2817-007	7817-007	10	0.08	0.35
1	2817-010	7817-010	10	0.14	0.38
1 1/2	2817-015	7817-015	10	0.25	0.48
2	2817-020	7817-020	10	0.37	0.61
3	2817-030	7817-030	5	0.80	0.79
4	2817-040	7817-040	5	1.54	1.02
6	2817-060	—	2	3.55	1.72

6106-3-3/6206-3-3 Thread* 45° ELL (FPT x FPT)

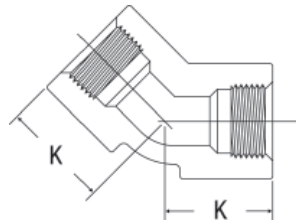

Nominal Size	Universal Part No.		Ctn. Qty.	Approx. Lbs./Ea.	Dim. K
	Black	Chem-Pure			
1/2	2819-005	7819-005	10	0.06	1.13
3/4	2819-007	7819-007	10	0.11	1.32
1	2819-010	7819-010	10	0.15	1.48
1 1/4	2819-012	7819-012	10	0.21	1.66
1 1/2	2819-015	7819-015	10	0.30	1.83
2	2819-020	7819-020	10	0.42	2.09
3	2819-030	7819-030	5	0.92	2.64
4	2819-040	7819-040	5	1.62	3.24

*Recommended for intermittent service not exceeding 29 psi.

6106-12 Flanged 90° ELL

Flanged fitting center-to-face dimensions may be found on page 29. When ordering, specify the figure number and the nominal size (e.g., 2" Schedule 80 PP Flanged Tee – 6106-12 2").

Couplings

Chemtrol
Fig. No.

6101/6201 Socket Couplings (S x S)

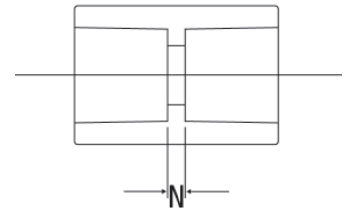

Nominal Size	Universal Part No.		Ctn. Qty.	Approx. Lbs./Ea.	Dim. N
	Black	Chem-Pure			
1/2	2829-005	7829-005	10	0.06	0.29
3/4	2829-007	7829-007	10	0.08	0.29
1	2829-010	7829-010	10	0.13	0.28
1 1/2	2829-015	7829-015	10	0.22	0.28
2	2829-020	7829-020	10	0.35	0.27
3	2829-030	7829-030	5	0.60	0.24
4	2829-040	7829-040	5	1.01	0.22
6	2829-060	—	2	2.37	0.26

6101-3-3/6201-3-3 Thread* Coupling (FPT x FPT)

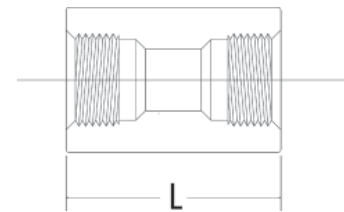

Nominal Size	Universal Part No.		Ctn. Qty.	Approx. Lbs./Ea.	Dim. L
	Black	Chem-Pure			
1/2	2830-005	7830-005	10	0.06	1.99
3/4	2830-007	7830-007	10	0.09	2.24
1	2830-010	7830-010	10	0.14	2.48
1 1/4	2830-012	7830-012	10	0.19	2.73
1 1/2	2830-015	7830-015	10	0.26	2.98
2	2830-020	7830-020	10	0.35	3.22
3	2830-030	7830-030	5	0.73	3.93
4	2830-040	7830-040	5	1.21	4.66

*Recommended for intermittent service not exceeding 20 psi.

*Chemtrol has seminars available to educate in the design and installation of thermoplastic piping systems. For more information, call our customer service department at **800.343.5455**.*

Do not use or test the products in this catalog with compressed air or other gases.

Adapters

Chemtrol
Fig. No.

6103/6203 Female Adapter Coupling (S x FPT*)

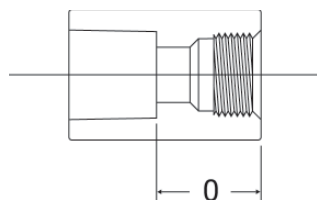

Nominal Size	Universal Part No.		Ctn. Qty.	Approx. Lbs./Ea.	Dim. O
	Black	Chem-Pure			
1/2	2835-005	7835-005	10	0.06	1.14
3/4	2835-007	7835-007	10	0.08	1.26
1	2835-010	7835-010	10	0.13	1.38
1 1/2	2835-015	7835-015	10	0.24	1.63
2	2835-020	7835-020	10	0.34	1.75
3	2835-030	7835-030	5	0.65	2.08
4	2835-040	7835-040	5	1.16	2.44

*Recommended for intermittent service not exceeding 20 psi.

6150 Tank Adapter (Tank x FPT*)

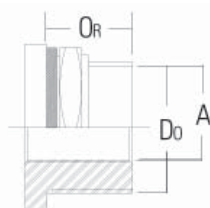

Nom. Size	Part No.	Ctn. Qty.	Approx. Lbs./Ea.	Dim. A	Dim. Or	Dim. Do
1/2	Use	5	0.20	14npt	1.19	1.63
3/4	Figure	5	0.30	14npt	1.19	1.63
1	No. &	5	0.31	11 1/2npt	1.38	2.50
1 1/4	Nom. Size	5	0.35	11 1/2npt	1.38	2.50
1 1/2		5	0.39	11 1/2npt	1.38	2.50
2		5	0.52	11 1/2npt	1.56	3.13
3		5	0.81	8npt	1.75	4.25

*Recommended for intermittent service not exceeding 20 psi.

Note: 1. Gasket is EPDM

For complete technical information and more, refer to our website at www.chemtrol.com.

Bushings

Chemtrol
Fig. No.

6118/6218 Flush Socket Reducer Bushing (SPG x S)

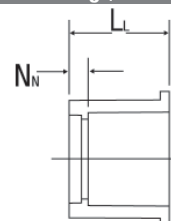

Nominal Size	Universal Part No.		Ctn. Qty.	Approx. Lbs./Ea.	Design Style†	Dim. L ₁	Dim. NN
	Black	Chem-Pure					
3/4 x 1/2	2837-101	7837-101	10	0.02	S	1.28	0.43
1 x 1/2	2837-130	7837-130	10	0.04	S	1.53	0.68
1 x 3/4	2837-131	7837-131	10	0.03	S	1.53	0.56
1 1/2 x 1	2837-211	7837-211	10	0.10	S	1.78	0.68
2 x 1	2837-249	7837-249	10	0.18	S	1.91	0.81
2 x 1 1/2	2837-251	7837-251	10	0.12	S	1.91	0.56
3 x 2	2837-338	7837-338	5	0.42	S	2.38	0.90
4 x 3	2837-422	7837-422	5	0.62	S	2.76	0.91
6 x 4	2837-532	—	2	1.74	S	3.00	0.78

Note: 3" and 4" sizes are hex head, 3/4", 1", 1 1/2", 2", and 6" have round heads.

† All Bushings have solid walls. See pg. 8 for detailed explanation.

6118-3-4/6218-3-4 Flush Thread* Reducer Bushing (MPT x FPT)

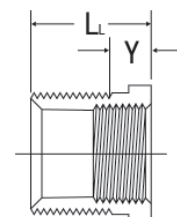

Nominal Size	Universal Part No.		Ctn. Qty.	Approx. Lbs./Ea.	Design Style†	Dim. L ₁	Dim. Y**
	Black	Chem-Pure					
3/4 x 1/2	2839-101	7839-101	10	0.02	S	1.27	0.43
1 x 1/2	2839-130	7839-130	10	0.04	S	1.53	0.43
1 x 3/4	2839-131	7839-131	10	0.03	S	1.53	0.45
1 1/4 x 3/4	2839-167	7839-167	10	0.09	S	1.38	0.45
1 1/4 x 1	2839-168	7839-168	10	0.07	S	1.38	0.53
1 1/2 x 1	2839-211	7839-211	10	0.11	S	1.55	0.53
1 1/2 x 1 1/4	2839-212	7839-212	10	0.07	S	1.55	0.55
2 x 1	2839-249	7839-249	10	0.18	S	1.57	0.53
2 x 1 1/2	2839-251	7839-251	10	0.13	S	1.57	0.55
3 x 2	2839-338	7839-338	5	0.38	S	2.38	0.57
4 x 3	2839-422	7839-422	5	0.49	S	2.76	0.95

* Recommended for intermittent service not exceeding 20 psi.

** Typical male component engagement, hand tight (L₁ in ANSI B1.20.1 thread spec.) plus 1 1/2 turns.

Note: 3/4", 1", 3", and 4" sizes are hex head; 1 1/4", 1 1/2", and 2" are knurled round.

† All Bushings have solid walls. See pg. 8 for detailed explanation.

Do not use or test the products in this catalog with compressed air or other gases.

Caps

Chemtrol
Fig. No.

6117/6217 Socket Cap[‡] (S)

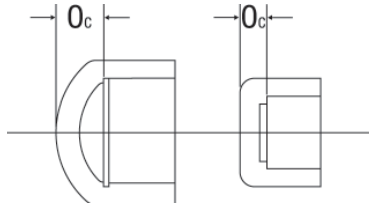

Nominal Size	Universal Part No. Black	Chem-Pure	Ctn. Qty.	Approx. Lbs./Ea.	Dim. O _c
1/2	2847-005	7847-005	10	0.04	0.41
3/4	2847-007	7847-007	10	0.05	0.38
1	2847-010	7847-010	10	0.09	0.42
1 1/2	2847-015	7847-015	10	0.17	0.42
2	2847-020	7847-020	10	0.23	0.42
3	2847-030	7847-030	5	0.52	1.29
4	2847-040	7847-040	5	0.90	1.57
6	2847-060	—	2	2.08	2.04

‡ Sizes 2" and smaller are flat; 3" and larger are domed.

Plugs

Chemtrol
Fig. No.

6116-4/6216-4 Thread* Plug (MPT)

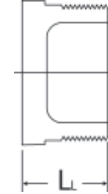

Nominal Size	Universal Part No. Black	Chem-Pure	Ctn. Qty.	Approx. Lbs./Ea.	Dim. L
1/2	2850-005	7850-005	10	0.02	1.15
3/4	2850-007	7850-007	10	0.02	1.27
1	2850-010	7850-010	10	0.04	1.53
1 1/4	2850-012	7850-012	5	0.13	1.57
1 1/2	2850-015	7850-015	5	0.16	1.55
2	2850-020	7850-020	5	0.25	1.55
3	2850-030	7850-030	5	0.33	2.38
4	2850-040	7850-040	5	0.66	2.76

* Recommended for intermittent service not exceeding 20 psi.

6117-3/6217-3 Thread* Cap[‡] (FPT)

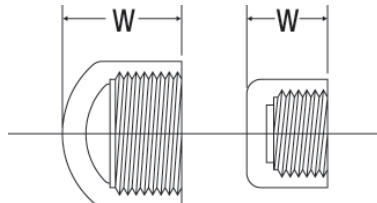

Nominal Size	Universal Part No. Black	Chem-Pure	Ctn. Qty.	Approx. Lbs./Ea.	Dim. W
1/2	2848-005	7848-005	10	0.04	1.26
3/4	2848-007	7848-007	10	0.08	1.36
1	2848-010	7848-010	10	0.09	1.52
1 1/4	2848-012	7848-012	10	0.13	1.63
1 1/2	2848-015	7848-015	10	0.19	1.77
2	2848-020	7848-020	10	0.26	1.90
3	2848-030	7848-030	5	0.58	3.13
4	2848-040	7848-040	5	1.02	3.79

* Recommended for intermittent service not exceeding 20 psi.

‡ Sizes 2" and smaller are flat; 3" and larger are domed.

Do not use or test the products in this catalog with compressed air or other gases.

Class 150 Flanges

Chemtrol
Fig. No.

6116-4/6216-4 Thread* Plug (MPT)

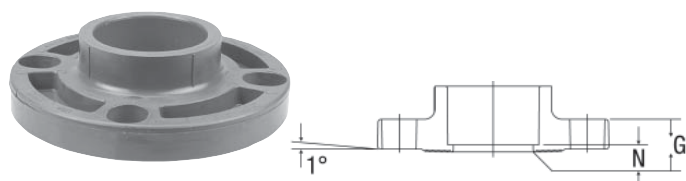

Nominal Size	Universal Part No.	Ctn. Qty.	Approx. Lbs./Ea.	Dim. G	Dim. N
2	2851-020	10	0.61	0.90	0.27
3	2851-030	5	1.16	1.12	0.34
4	2851-040	5	1.69	1.23	0.33
6	2851-060	2	2.66	1.33	0.28

Note: One-piece webbed flanges have oblong bolt holes which permit mating with ANSI B16.5, 150 lb.; BS 1560, class 150; ISO 2084, PN10; and DIN 2532, PN10 flanges.

6151-H/6251-H Socket Flange (S), One-Piece (Solid)

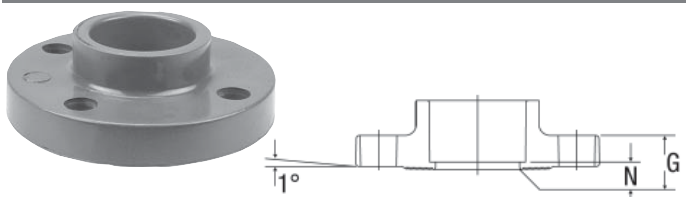

Nominal Size	Universal Part No.		Ctn. Qty.	Approx. Lbs./Ea.	Dim. G	Dim. N
	Black	Chem-Pure				
1/2	2851-H05	7851-H05	10	0.13	0.54	0.23
3/4	2851-H07	7851-H07	10	0.20	0.60	0.20
1	2851-H10	7851-H10	10	0.24	0.67	0.21
1 1/2	2851-H15	7851-H15	10	0.41	0.72	0.23
2	2851-H20	7851-H20	10	0.79	0.90	0.27
3	2851-H30	7851-H30	5	1.50	1.12	0.34
4	2851-H40	7851-H40	5	2.20	1.23	0.33
6	2851-H60	—	2	3.45	1.33	0.28

6151-W-3/6215-W-3 Thread* Flange (FPT), One-Piece (Webbed Design)

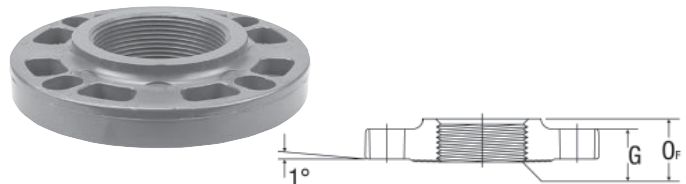

Nominal Size	Universal Part No.		Ctn. Qty.	Approx. Lbs./Ea.	Dim. G	Dim. OF
	Black	Chem-Pure				
2	2852-020	7852-020	5	0.56	0.90	1.17
3	2852-030	7852-030	5	0.98	1.12	1.53
4	2852-040	7852-040	5	1.62	1.23	1.65

* Recommended for intermittent service not exceeding 20 psi.

Note: One-piece webbed flanges have oblong bolt holes which permit mating with ANSI B16.5, 150 lb.; BS 1560, class 150; ISO 2084, PN10; and DIN 2532, PN10 flanges.

Chemtrol
Fig. No.

6151-H-3/6251-H-3 Thread* Flange (FPT), One-Piece (Solid)

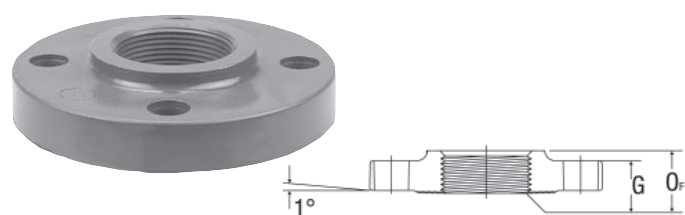

Nominal Size	Universal Part No.		Ctn. Qty.	Approx. Lbs./Ea.	Dim. G	Dim. OF
	Black	Chem-Pure				
1/2	2852-H05	7852-H05	10	0.13	0.54	0.87
3/4	2852-H07	7852-H07	10	0.18	0.60	0.90
1	2852-H10	7852-H10	10	0.24	0.67	1.07
1 1/4	2852-H12	7852-H12	5	0.34	0.65	1.11
1 1/2	2852-H15	7852-H15	5	0.39	0.72	1.07
2	2852-H20	7852-H20	5	0.71	0.90	1.17
3	2852-H30	7852-H30	5	1.22	1.12	1.53
4	2852-H40	7852-H40	5	2.03	1.23	1.65

* Recommended for intermittent service not exceeding 20 psi.

6119-W Blind Flange, One-Piece (Webbed Design)

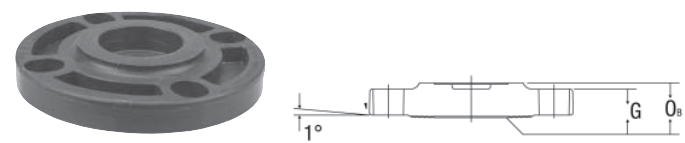

Nominal Size	Universal Part No.	Ctn. Qty.	Approx. Lbs./Ea.	Dim. G	Dim. OB
2	2853-020	5	0.59	0.90	1.11
3	2853-030	5	1.14	1.12	1.37
4	2853-040	5	1.94	1.23	1.49
6	2853-060	2	3.08	1.33	1.53

Note: One-piece webbed flanges have oblong bolt holes which permit mating with ANSI B16.5, 150 lb.; BS 1560, class 150; ISO 2084, PN10; and DIN 2532, PN10.

6119-H/6219-H Blind Flange, One-Piece (Solid)

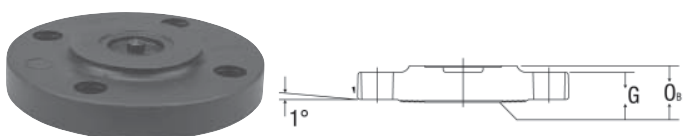

Nominal Size	Universal Part No.		Ctn. Qty.	Approx. Lbs./Ea.	Dim. G	Dim. OB
	Black	Chem-Pure®				
1/2	2853-H05	7853-H05	10	0.13	0.54	0.75
3/4	2853-H07	7853-H07	10	0.20	0.60	0.82
1	2853-H10	7853-H10	10	0.26	0.67	0.87
1 1/4	2853-H12	—	10	0.32	0.65	0.89
1 1/2	2853-H15	7853-H15	10	0.39	0.72	0.98
2	2853-H20	7853-H20	5	0.82	0.90	1.11
3	2853-H30	7853-H30	5	1.74	1.12	1.37
4	2853-H40	7853-H40	5	2.70	1.23	1.49
6	2853-H60	—	2	4.28	1.33	1.53

Do not use or test the products in this catalog with compressed air or other gases.

Chemtrol
Fig. No.

Flanged Fittings*— Fabricated from Molded Components

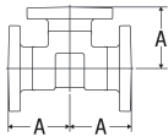

Fig. No. 6111-12
Flanged Tee

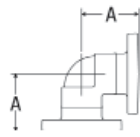

Fig. No. 6107-12
Flanged 90° ELL

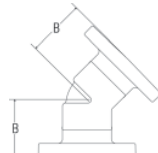

Fig. No. 6106-12
Flanged 45° ELL

Nominal Size	Fig. No. 6111-12 Flanged Tee		Fig. No. 6107-12 Flanged 90° ELL		Fig. No. 6106-12 Flanged 45° ELL	
	Approx. Lbs./Ea.	Dim. A	Approx. Lbs./Ea.	Dim. A	Approx. Lbs./Ea.	Dim. B
1/2	0.24	2 13/32	0.21	2 13/32	0.21	2 5/32
3/4	0.37	2 23/32	0.31	2 23/32	0.31	2 15/32
1	0.48	3 3/32	0.44	3 3/32	0.43	2 23/32
1 1/2	0.94	3 31/32	0.83	3 31/32	0.76	3 13/32
2	1.64	5 7/32	1.44	4 15/32	1.32	3 27/32
3	4.97	5 15/32	3.04	5 13/32	2.70	4 25/32
4	5.30	7 3/32	4.82	7 3/32	4.43	5 25/32

*Flanged fittings are produced by heat fusion of socket flanges to socket fittings with short plain end pipe nipples. They may be ordered as factory fabrications or may be assembled in the field. See also plain end pipe nipples on page 31.

NR 51 Flange Gaskets, for Class 150 Flanges

Note: These gaskets are 1/8" thick, full face polychloroprene (CR), 70 durometer.



Nominal Size	Part No.	Approx. Lbs./Ea.
1/2	↑	0.11
3/4		0.12
1		0.13
1 1/4		0.14
1 1/2	Use	0.15
2	Figure No.	0.20
2 1/2	& Nom. Size	0.25
3	↓	0.28
4		0.30
6		0.40
8		0.50

Unions

Chemtrol
Fig. No.

6133/6233 FKM Socket Union (S x S)

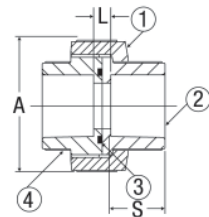
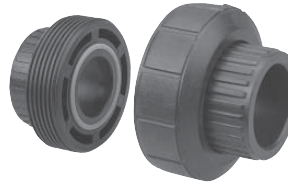

Nominal Size	Universal Black	Part No. Chem-Pure	Ctn. Qty.	Approx. Lbs./Ea.	Dim. A	Dim. L	Dim. S*
1/2	2897-005	7897-005	10	0.11	1.98	0.46	0.85
3/4	2897-007	7897-007	10	0.20	2.41	0.50	0.98
1	2897-010	7897-010	10	0.28	2.77	0.48	1.10
1 1/2	2897-015	7897-015	5	0.70	4.04	0.79	1.35
2	2897-020	7897-020	5	1.31	5.20	0.82	1.48

Unions are supplied with FKM O-Rings. EPDM O-Rings may be ordered for field replacement, where required. Socket x Thread is available on request. Threaded fittings are recommended for intermittent service not exceeding 20 psi.

* Socket Depth

6133-3-3/6233-3-3 FKM Threaded* Union (FPT x FPT)

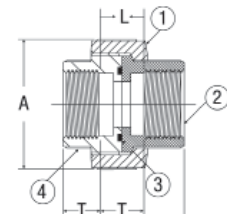
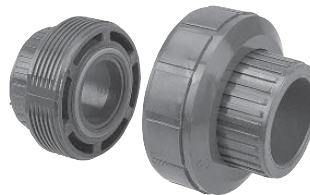

Nominal Size	Universal Black	Part No. Chem-Pure	Ctn. Qty.	Approx. Lbs./Ea.	Dim. A	Dim. L	Dim. T**
1/2	2898-005	7898-005	10	0.12	1.17	1.30	0.43
3/4	2898-007	7898-007	10	0.20	2.41	1.55	0.45
1	2898-010	7898-010	10	0.29	2.77	1.62	0.53
1 1/4	2898-012	7898-012	5	0.67	4.04	2.17	0.55
1 1/2	2898-015	7898-015	5	0.74	4.04	2.39	0.55
2	2898-020	7898-020	5	1.39	5.20	2.63	0.57

Unions are supplied with FKM O-Rings. EPDM O-Rings may be ordered for field replacement, where required. Socket x Thread is available on request.

* Recommended for intermittent service not exceeding 20 psi.

** Thread Joint Engagement

*Chemtrol sells its products through a select group of highly trained distributors. Please call **800.343.5455** for a listing of distributors in your area.*

Do not use or test the products in this catalog with compressed air or other gases.

Transition Unions

Chemtrol
Fig. No.

- TCBR-3 Brass End Connector (FPT)
- TCBR-4 Brass End Connector (MPT)
- TCSS-3 Stainless Steel End Connector (FPT)
- TCSS-4 Stainless Steel End Connector (MPT)

Refer to page 13 for purchase and assembly instructions of Transition Unions and for part number, size, carton quantity, weights, and dimensions of Metal End Connectors.

Nipples

6129 Threaded* Pipe Nipple (MPT x MPT)

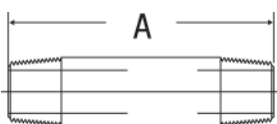

Length – 2"			Example of part identification					
Nom. Size	Ctn. Qty.	Approx. Lbs./Ea.	1/2" x Short PP Nipple – 6129 1/2" – SH					
1/2	10	0.02						

Nom. Size	Length – Close			Length – Short			Length – 3"		
	Ctn. Qty.	Approx. Lbs./Ea.	Dim. A	Ctn. Qty.	Approx. Lbs./Ea.	Dim. A	Ctn. Qty.	Approx. Lbs./Ea.	
1/2	10	0.01	1.13	10	0.01	1.50	10	0.03	
3/4	10	0.02	1.38	10	0.03	2.00	10	0.04	
1	10	0.03	1.50	10	0.04	2.00	10	0.06	
1 1/4	10	0.04	1.63	10	0.06	2.50	10	0.08	
1 1/2	10	0.06	1.75	10	0.08	2.50	10	0.10	
2	10	0.09	2.00	10	0.11	2.50	10	0.14	
3	5	0.21	2.63	5	0.26	3.00	See Short		
4	5	0.35	2.88	5	0.50	4.00	See Close		

Chemtrol
Fig. No.

6129 Threaded* Pipe Nipple (MPT x MPT) (cont.)

Nom. Size	Length – 4"		Length – 5"		Length – 6"	
	Ctn. Qty.	Approx. Lbs./Ea.	Ctn. Qty.	Approx. Lbs./Ea.	Ctn. Qty.	Approx. Lbs./Ea.
1/2	10	0.04	10	0.05	10	0.06
3/4	10	0.06	10	0.07	10	0.09
1	10	0.08	10	0.10	10	0.12
1 1/4	10	0.12	10	0.14	10	0.18
1 1/2	10	0.14	10	0.18	10	0.21
2	10	0.20	10	0.24	10	0.30
3	5	0.37	5	0.46	5	0.59
4	See Short		5	0.72	5	0.85

*Recommended for intermittent service not exceeding 20 psi.

6131 Plain End Pipe Nipple (SPG x SPG)

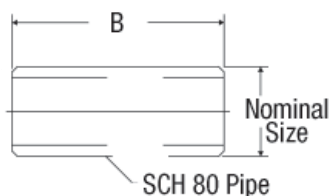

Used for solvent cementing for joining any Sch. 80 polypropylene fitting face-to-face.

Nominal Size	Part Number	Ctn. Qty.	Approx. Lbs./Ea.	Dim. B
1/2	↑ Use Figure No. & Nom. Size ↓	6	0.02	1.62
3/4		10	0.03	2.86
1		10	0.05	2.08
1 1/2		10	0.10	2.56
2		10	0.16	2.77
3		6	0.40	3.48
4	6	0.69	4.26	
6	3	1.80	5.70	

Do not use or test the products in this catalog with compressed air or other gases.

Pipe

Chemtrol
Fig. No.

6500/6600-80 (1/2"-6") Plain End Schedule 80 Pipe (20 ft. Lengths)

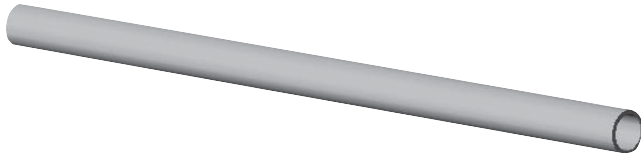

Pipe is ordered and specified with the Chemtrol figure number followed by the nominal size (e.g., 1 1/2" Schedule 80 PVDF Pipe – 6500-80- 1 1/2"). Weights and dimensions for all pipe may be found on page 40 of this catalog.

Tees

6511/6611 Socket Tee (S x S x S)

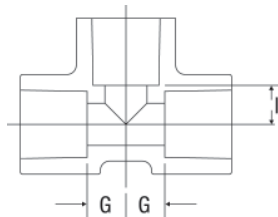

Nominal Size	Universal Part No. Red	Natural	Ctn. Qty.	Approx. Lbs./Ea.	Dim. G	Dim. I
1/2	3801-005	4801-005	5	0.16	0.52	0.52
3/4	3801-007	4801-007	5	0.29	0.69	0.69
1	3801-010	4801-010	5	0.47	0.74	0.74
1 1/2	3801-015	4801-015	2	0.79	1.04	1.04
2	3801-020	4801-020	2	1.36	1.23	1.23
3	3801-030	4801-030	2	2.61	1.80	1.80
4	3801-040	4801-040	2	4.50	2.28	2.28
6	3801-060	4801-060	1	11.33	3.39	3.39

6512-3-3/6612-3-3 Thread Tee (FPT x FPT x FPT)

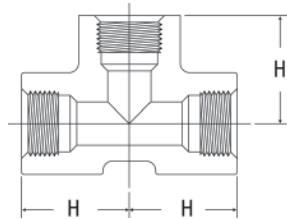

Nominal Size	Universal Part No. Red	Natural	Ctn. Qty.	Approx. Lbs./Ea.	Dim. H
1/2	3805-005	4805-005	5	0.18	1.37
3/4	3805-007	4805-007	5	0.30	1.60
1	3805-010	4805-010	5	0.44	1.84
1 1/2	3805-015	4805-015	2	0.92	2.39
2	3805-020	4805-020	2	1.31	2.71

Elbows

Chemtrol
Fig. No.

6507/6607 Socket 90° ELL (S x S)

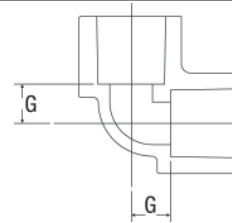

Nominal Size	Universal Part No. Red	Natural	Ctn. Qty.	Approx. Lbs./Ea.	Dim. G
1/2	3806-005	4806-005	5	0.12	0.52
3/4	3806-007	4806-007	5	0.18	0.69
1	3806-010	4806-010	5	0.28	0.74
1 1/2	3806-015	4806-015	2	0.56	1.04
2	3806-020	4806-020	2	0.95	1.23
3	3806-030	4806-030	2	2.51	1.80
4	3806-040	4806-040	2	4.02	2.28
6	3806-060	4806-060	1	9.76	3.39

6507-3-3/6607-3-3 Thread 90° ELL (FPT x FPT)

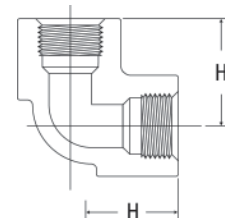

Nominal Size	Universal Part No. Red	Natural	Ctn. Qty.	Approx. Lbs./Ea.	Dim. H
1/2	3808-005	4808-005	5	0.13	1.37
3/4	3808-007	4808-007	5	0.20	1.60
1	3808-010	4808-010	5	0.32	1.84
1 1/2	3808-015	4808-015	2	0.64	2.39
2	3808-020	4808-020	2	0.80	2.71

6506/6606 Socket 45° ELL (S x S)

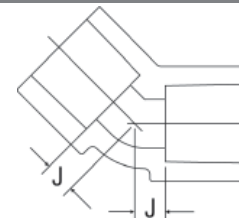

Nominal Size	Universal Part No. Red	Natural	Ctn. Qty.	Approx. Lbs./Ea.	Dim. J
1/2	3817-005	4817-005	5	0.10	0.27
3/4	3817-007	4817-007	5	0.14	0.33
1	3817-010	4817-010	5	0.29	0.37
1 1/2	3817-015	4817-015	2	0.49	0.46

Chemtrol
Fig. No.

6506/6607 Socket 45° ELL (S x S) (cont.)

Nominal Size	Universal Part No.		Ctn. Qty.	Approx. Lbs./Ea.	Dim. J
	Red	Natural			
2	3817-020	4817-020	2	0.68	0.59
3	3817-030	4817-030	2	1.53	0.77
4	3817-040	4817-040	2	2.71	0.99
6	3817-060	4817-060	1	6.40	1.69

6506-3-3/6606-3-3 Thread 45° ELL (FPT x FPT)

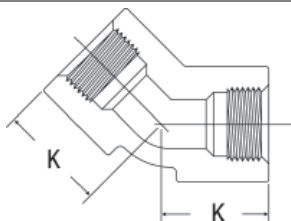

Nominal Size	Universal Part No.		Ctn. Qty.	Approx. Lbs./Ea.	Dim. K
	Red	Natural			
1/2	3819-005	4819-005	5	0.12	1.12
3/4	3819-007	4819-007	5	0.18	1.31
1	3819-010	4819-010	5	0.29	1.47
1 1/2	3819-015	4819-015	2	0.55	1.81
2	3819-020	4819-020	2	0.80	2.07

Couplings

6501/6601 Socket Coupling (S x S)

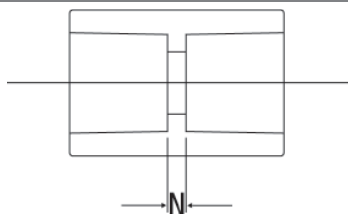

Nominal Size	Universal Part No.		Ctn. Qty.	Approx. Lbs./Ea.	Dim. N
	Red	Natural			
1/2	3829-005	4829-005	5	0.12	0.28
3/4	3829-007	4829-007	5	0.16	0.27
1	3829-010	4829-010	5	0.26	0.26
1 1/2	3829-015	4829-015	2	0.49	0.25
2	3829-020	4829-020	2	0.71	0.24
3	3829-030	4829-030	2	1.43	0.21
4	3829-040	4829-040	2	2.47	0.19
6	3829-060	4829-060	1	5.49	0.21

Chemtrol
Fig. No.

6501-3-3/6601-3-3 Thread Coupling (FPT x FPT)

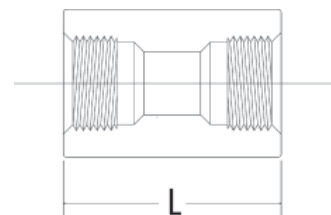

Nominal Size	Universal Part No.		Ctn. Qty.	Approx. Lbs./Ea.	Dim. L
	Red	Natural			
1/2	3830-005	4830-005	5	0.12	1.98
3/4	3830-007	4830-007	5	0.16	2.22
1	3830-010	4830-010	5	0.56	2.46
1 1/2	3830-015	4830-015	2	0.49	2.95
2	3830-020	4830-020	2	0.71	3.19

Adapters

6503/6603 Female Adapter Coupling (S x FPT)

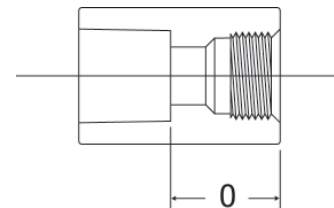

Nominal Size	Universal Part No.		Ctn. Qty.	Approx. Lbs./Ea.	Dim. O
	Red	Natural			
1/2	3835-005	4835-005	5	0.12	1.13
3/4	3835-007	4835-007	5	0.16	1.25
1	3835-010	4835-010	5	0.26	1.36
1 1/2	3835-015	4835-015	2	0.49	1.60
2	3835-020	4835-020	2	0.71	1.72

For complete technical information and more, refer to our website at www.chemtrol.com.

Bushings

Chemtrol
Fig. No.

6518/6618 Flush Socket Reducer Bushing (SPG x S)

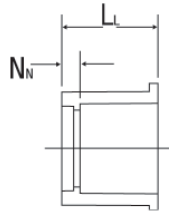

Nominal Size	Universal Part No.		Ctn. Qty.	Approx. Lbs./Ea.	Design Style*	Dim. L _L	Dim. N _N
	Red	Natural					
3/4 x 1/2	3837-101	4837-101	5	0.08	S	1.40	0.55
1 x 3/4	3837-131	4837-131	5	0.08	S	1.52	0.55
1 1/2 x 1	3837-249	4837-168	5	0.34	S	1.79	0.69
2 x 1	3837-249	4837-249	5	0.63	S	1.89	0.79
2 x 1 1/2	3837-251	4837-251	5	0.50	S	1.89	0.54
3 x 2	3837-338	4837-338	5	0.88	S	2.36	0.88
4 x 3	3837-422	4837-442	5	1.36	S	2.74	0.89
6 x 4	3837-532	4837-532	2	4.67	S	2.98	0.76

* All Bushings have solid walls. See pg. 8 for detailed explanation.

6518-3-4/6618-3-4 Flush Thread Reducer Bushing (MPT x FPT)

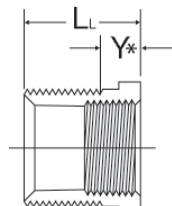
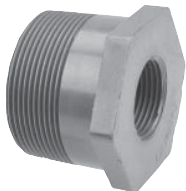

Nominal Size	Universal Part No.		Ctn. Qty.	Approx. Lbs./Ea.	Design Style	Dim. L _L	Dim. Y*
	Red	Natural					
3/4 x 1/2	3839-101	4839-101	5	0.05	S	1.26	0.43
1 x 1/2	3839-130	4839-130	5	0.16	S	1.52	0.43
1 x 3/4	3839-131	4839-131	5	0.08	S	1.52	0.45
1 1/2 x 1	3839-211	4839-211	5	0.19	S	1.79	0.53
2 x 1	3839-249	4839-249	5	0.35	S	1.89	0.53
2 x 1 1/2	3839-251	4839-251	5	0.22	S	1.89	0.55

* Typical male component engagement, hand tight (L_L in ANSI B1.20.1 thread spec.) plus 1 1/2 turns plus.

** All Bushings have solid walls. See pg. 8 for detailed explanation.

Caps

Chemtrol
Fig. No.

6517/6617 Socket Cap (S)

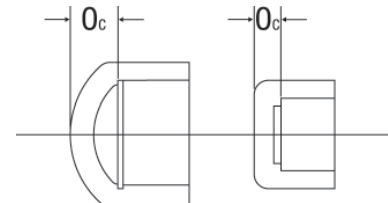

Nominal Size	Universal Part No.		Ctn. Qty.	Approx. Lbs./Ea.	Dim. O _c
	Red	Natural			
1/2	3847-005	4847-005	5	0.07	0.40
3/4	3847-007	4847-007	5	0.10	0.37
1	3847-010	4847-010	5	0.17	0.41
1 1/2	3847-015	4847-015	2	0.29	0.40
2	3847-020	4847-020	2	0.48	0.41

Note: Caps are flat top style.

6517-3/6617-3 Thread Cap (FPT)

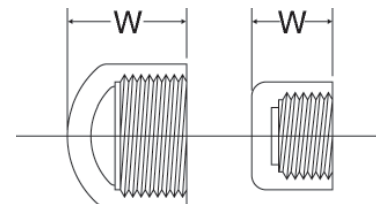

Nominal Size	Universal Part No.		Ctn. Qty.	Approx. Lbs./Ea.	Dim. W
	Red	Natural			
1/2	3848-005	4848-005	5	0.07	1.25
3/4	3848-007	4848-007	5	0.10	1.34
1	3848-010	4848-010	5	0.17	1.51
1 1/2	3848-015	4848-015	2	0.33	1.75
2	3848-020	4848-020	2	0.48	1.88

For questions concerning thermoplastic piping systems, please call or fax: **888.446.4226 (ph)**, **888.336.4226 (fx)**.

Plugs

Chemtrol
Fig. No.

6516-4/6616-4 Thread Plug (MPT)

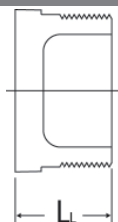

Nominal Size	Universal Part No.		Ctn. Qty.	Approx. Lbs./Ea.	Dim. L _t
	Red	Natural			
1/2	3850-005	4850-005	5	0.03	1.14
3/4	3850-007	4850-007	5	0.08	1.26
1	3850-010	4850-010	5	0.10	1.48
1 1/2	3850-015	4850-015	2	0.18	1.78
2	3850-020	4850-020	2	0.26	1.89

Class 150 Flanges

6551-W/6651-W Socket Flange (S), One-Piece (Webbed Design)

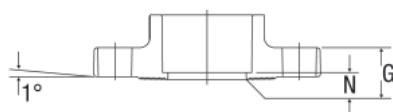
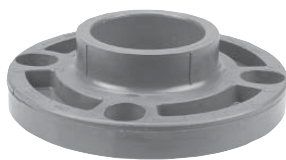

Nominal Size	Universal Part No.		Ctn. Qty.	Approx. Lbs./Ea.	Dim. G	Dim. N
	Red	Natural				
2	3851-020	4851-020	2	0.89	0.90	0.27
3	3851-030	4851-030	2	1.97	1.10	0.34
4	3851-040	4851-040	2	2.97	1.21	0.31
6	3851-060	4851-060	1	4.54	1.32	0.21

Note: One-piece webbed flanges have oblong bolt holes which permit mating with ANSI B16.5, 150lb.; BS 1560, class 150; ISO 2084, PN10; and DIN 2532, PN10.

6551-H/6651-H Socket Flange (S), One-Piece (Solid)

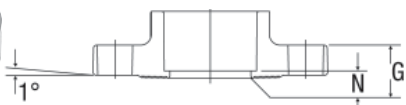

Nominal Size	Universal Part No.		Ctn. Qty.	Approx. Lbs./Ea.	Dim. G	Dim. N
	Red	Natural				
1/2	3851-H05	4851-H05	5	0.25	0.53	0.19
3/4	3851-H07	4851-H07	5	0.33	0.59	0.20
1	3851-H10	4851-H10	5	0.48	0.66	0.21
1 1/2	3851-H15	4851-H15	2	0.75	0.72	0.23
2	3851-H20	4851-H20	2	1.16	0.90	0.27
3	3851-H30	4851-H30	2	2.56	1.10	0.34
4	3851-H40	4851-H40	2	3.86	1.21	0.31
6	3851-H60	4851-H60	1	5.89	1.32	0.21

Kynar® is a registered trademark of Arkema Inc.

Chemtrol
Fig. No.

6551-W-3/6651-W-3 Thread Flange (FPT), One-Pc (Webbed Design)

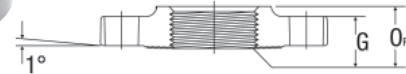
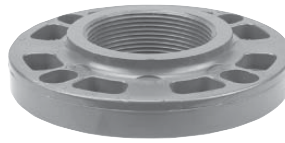

Nominal Size	Universal Part No.		Ctn. Qty.	Approx. Lbs./Ea.	Dim. G	Dim. O _F
	Red	Natural				
2	3852-020	4852-020	2	0.88	0.90	1.15

Note: One-piece webbed flanges have oblong bolt holes which permit mating with ANSI B16.5, 150 lb.; BS 1560, class 150; ISO 2084, PN10; and DIN 2532, PN10.

6551-H-3/6651-H-3 Thread Flange (FPT), One Piece (Solid)

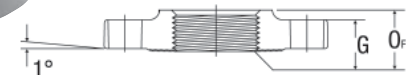
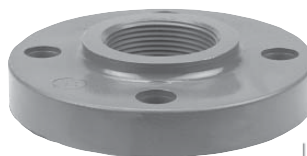

Nominal Size	Universal Part No.		Ctn. Qty.	Approx. Lbs./Ea.	Dim. G	Dim. O _F
	Red	Natural				
1/2	3852-H05	4852-H05	5	0.25	0.53	0.87
3/4	3852-H07	4852-H07	5	0.34	0.59	0.88
1	3852-H10	4852-H10	5	0.47	0.66	1.07
1 1/2	3852-H15	4852-H15	2	0.71	0.72	1.11
2	3852-H20	4852-H20	2	1.10	0.90	1.15

6519-W/6619-W Blind Flange, One-Piece (Webbed Design)

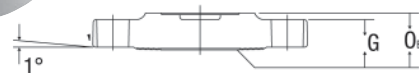

Nominal Size	Universal Part No.		Ctn. Qty.	Approx. Lbs./Ea.	Dim. G	Dim. O _B
	Red	Natural				
2	3853-020	4853-020	2	0.91	0.90	1.10
3	3853-030	4853-030	2	2.08	1.10	1.36
4	3853-040	4853-040	2	3.02	1.21	1.45
6	3853-060	4853-060	1	5.33	1.32	1.58

Note: One-piece webbed flanges have oblong bolt holes which permit mating with ANSI B16.5, 150 lb.; BS 1560, class 150; ISO 2084, PN10; and DIN 2532, PN10.

Do not use or test the products in this catalog with compressed air or other gases.

Chemtrol
Fig. No.

6519-H/6619-H Blind Flange, One-Piece (Solid)

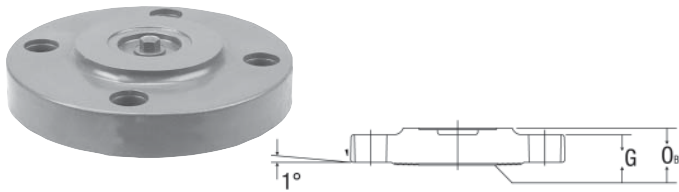

Nominal Size	Universal Part No. Red	Universal Part No. Natural	Ctn. Qty.	Approx. Lbs./Ea.	Dim. G	Dim. O _B
1/2	3853-H05	4853-H05	5	0.25	0.53	0.74
3/4	3853-H07	4853-H07	5	0.37	0.59	0.81
1	3853-H10	4853-H10	5	0.51	0.66	0.87
1 1/2	3853-H15	4853-H15	2	0.82	0.72	0.98
2	3853-H20	4853-H20	2	1.27	0.90	1.10
3	3853-H30	4853-H30	2	2.89	1.10	1.36
4	3853-H40	4853-H40	2	4.20	1.21	1.45
6	3853-H60	4853-H60	1	7.40	1.32	1.58

NR 51 Flange Gaskets, for Class 150 Flanges

Note: These gaskets are 1/8" thick, full face Polychloroprene (CR), 70 durometer.

Nominal Size	Part No.	Approx. Lbs./Ea.
1/2	↑	0.11
3/4	↑	0.12
1	Use Figure No.	0.13
1 1/4	& Nom. Size	0.14
1 1/2	↓	0.15
2	↓	0.20

See page 12 for additional sizes.

Flanged Fittings*— Fabricated from Molded Components

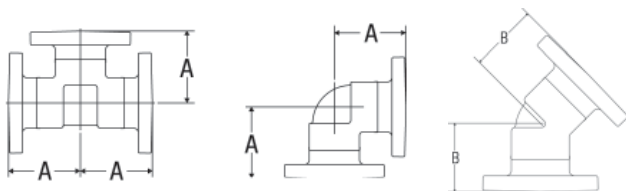

Nominal Size	Fig. No. 6511-12 6611-12 Flanged Tee		Fig. No. 6507-12 6607-12 Flanged 90° ELL		Fig. No. 6506-12 6606-12 Flanged 45° ELL	
	Approx. Lbs./Ea.	Dim. A	Approx. Lbs./Ea.	Dim. A	Approx. Lbs./Ea.	Dim. B
1/2	0.45	2 13/32	0.41	2 13/32	0.39	2 5/32
3/4	0.68	2 23/32	0.57	2 23/32	0.53	2 15/32
1	1.04	3 3/32	0.85	3 3/32	0.86	2 23/32
1 1/2	1.73	3 31/32	1.50	3 31/32	1.43	3 13/32
2	2.80	4 15/32	2.39	4 15/32	2.12	3 27/32

*Flanged fittings are produced by heat fusion of socket flanges to socket fittings with short plain end pipe nipples. They may be ordered as factory fabrications or may be assembled in the field. See also plain end pipe nipples on page 36.

Unions

Chemtrol
Fig. No.

6533/6633 FKM Socket Union (S x S)

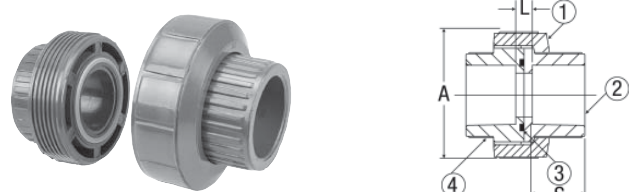

Nominal Size	Universal Part No. Red	Universal Part No. Natural	Approx. Lbs./Ea.	Dim. A	Dim. L	Dim. S*
1/2	3897-005	4897-005	0.17	1.95	0.43	0.85
3/4	3897-007	4897-007	0.31	2.36	0.48	0.98
1	3897-010	4897-010	0.46	2.75	0.44	1.10
1 1/2	3897-015	4897-015	1.04	3.98	0.78	1.35
2	3897-020	4897-020	2.17	5.13	0.80	1.48

Unions are supplied with FKM O-Rings. EPDM O-Rings may be ordered for field replacement, where required. Socket x Thread is available on request.

*Socket Depth

6533-3-3/6633-3-3 FKM Socket Union (FPT x FPT)



Nominal Size	Universal Part No. Red	Universal Part No. Natural	Approx. Lbs./Ea.	Dim. A	Dim. L	Dim. T*
1/2	3898-005	4898-005	0.18	1.95	1.27	0.43
3/4	3898-007	4898-007	0.32	2.36	1.53	0.45
1	3898-010	4898-010	0.47	2.75	1.58	0.53
1 1/2	3898-015	4898-015	1.11	3.98	2.38	0.55
2	3898-020	4898-020	2.24	5.13	2.61	0.57

Unions are supplied with FKM O-Rings. EPDM O-Rings may be ordered for field replacement, where required. Socket x Thread is available on request.

* Thread Joint Engagement

Transition Unions

Materials of Construction

Item	Description	Material
1	Union Nut	CPVC
2	End Connector	Brass/SS
3	O-Ring	EPDM
4	Union Tailpiece	CPVC

TCBR-3 Brass End Connector (FPT)
 TCBR-4 Brass End Connector (MPT)
 TCSS-3 Stainless Steel End Connector (FPT)
 TCSS-4 Stainless Steel End Connector (MPT)

Refer to page 13 for purchase and assembly instructions of Transition Unions and for part number, size, carton, weights, and dimensions of Metal End Connectors.

Nipples

Chemtrol
 Fig. No.

6529/6629 Threaded Pipe Nipple (MPT x MPT)

Example of part identification 1/2" x Short PVDF Nipple – 6129 1/2" – SH

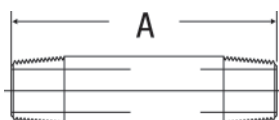

Nom. Size	Length – Close			Length – Short			Length – 3"		
	Ctn. Qty.	Approx. Lbs./Ea.	Dim. A	Ctn. Qty.	Approx. Lbs./Ea.	Dim. A	Ctn. Qty.	Approx. Lbs./Ea.	
1/2	5	0.02	1.13	5	0.03	1.50	5	0.06	
3/4	5	0.04	1.38	5	0.05	2.00	5	0.08	
1	5	0.06	1.50	5	0.07	2.00	5	0.12	
1 1/2	5	0.13	1.75	5	0.15	2.50	5	0.19	
2	5	0.20	2.00	5	0.23	2.50	5	0.27	

Nom. Size	Length – 4"		Length – 5"		Length – 6"	
	Ctn. Qty.	Approx. Lbs./Ea.	Ctn. Qty.	Approx. Lbs./Ea.	Ctn. Qty.	Approx. Lbs./Ea.
1/2	5	0.08	5	0.10	5	0.12
3/4	5	0.11	5	0.14	5	0.17
1	5	0.17	5	0.21	5	0.25
1 1/2	5	0.26	5	0.34	5	0.41
2	5	0.38	5	0.48	5	0.60

Chemtrol
 Fig. No.

6531/6631 Plain End Pipe Nipple (SPG x SPG)

Used for fusion joining flanges to fitting or for joining any Sch. 80 fitting face-to-face.

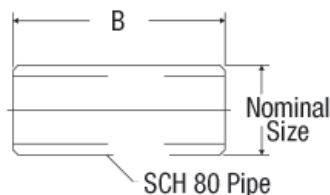

Nominal Size	Universal Part No.	Ctn. Qty.	Approx. Lbs./Ea.	Dim. B
1/2		12	0.04	1.63
3/4	Use Figure No.	12	0.06	1.86
1	&	12	0.09	2.08
1 1/2	Nom. Size	12	0.16	2.56
2		12	0.28	2.77
3		1	0.78	3.75

For complete technical information and more, refer to our website at www.chemtrol.com.

Metric Equivalent Charts

Linear Conversion Table From Fractional Inches to Millimeters

inches	mm	inches	mm		
1/64	.016	.397	33/64	.516	13.097
1/32	.031	.794	17/32	.531	13.494
3/64	.047	1.191	35/64	.547	13.891
1/16	.063	1.588	9/16	.563	14.288
5/64	.078	1.984	37/64	.578	14.684
3/32	.094	2.381	19/32	.594	15.081
7/64	.109	2.778	39/64	.609	15.478
1/8	.125	3.175	5/8	.625	15.875
9/64	.141	3.572	41/64	.641	16.272
5/32	.156	3.969	21/32	.656	16.669
11/64	.172	4.366	43/64	.672	17.066
3/16	.188	4.763	11/16	.688	17.463
13/64	.203	5.159	45/64	.703	17.859
7/32	.219	5.556	23/32	.719	18.256
15/64	.234	5.953	47/64	.734	18.653
1/4	.250	6.350	3/4	.750	19.050
17/64	.266	6.747	49/64	.766	19.447
9/32	.281	7.144	25/32	.781	19.844
19/64	.297	7.541	51/64	.797	20.241
5/16	.313	7.938	13/16	.813	20.638
21/64	.328	8.334	53/64	.828	21.034
11/32	.344	8.731	27/32	.844	21.431
23/64	.359	9.128	55/64	.859	21.828
3/8	.375	9.525	7/8	.875	22.225
25/64	.391	9.922	57/64	.891	22.622
13/32	.406	10.319	29/32	.906	23.019
27/64	.422	10.716	59/64	.922	23.416
7/16	.438	11.113	15/16	.938	23.813
29/64	.453	11.509	61/64	.953	24.209
15/32	.469	11.906	31/32	.969	24.606
31/64	.484	12.303	63/64	.984	25.003
1/2	.500	12.700	1	1.000	25.400

1 inch = 25.4 millimeters

English to Metric Conversion Table

Units	Change to	Multiply by
Inches	Millimeters	25.40
Inches	Centimeters	2.54
Inches	Meters	.0254
Feet	Meters	.3048
Miles	Kilometers	1.609347
Sq. Inches	Sq. Centimeters	6.452
Sq. Feet	Sq. Meters	.0929
Cu. Inches	Cu. Centimeters	16.3872
Cu. Feet	Cu. Meters	.02832
U.S. Gallons	Liters	3.7854
Pounds	Kilograms	.45359

Metric to English Conversion Table

Units	Change to	Multiply by
Millimeters	Inches	.03937
Centimeters	Inches	.39371
Meters	Inches	39.371
Meters	Feet	3.281
Kilometers	Miles	.62137
Sq. Centimeters	Sq. Inches	.1550
Sq. Meters	Sq. Feet	10.7649
Cu. Centimeters	Cu. Inches	.061
Cu. Meters	Cu. Feet	35.314
Liters	U.S. Gallons	.26417
Kilograms	Pounds	2.20462

Physical Properties of Thermoplastic Piping Materials

ASTM Test Methods	Properties	Material			
		PVC 12454-B	CPVC 23447-B	PVDF	Polypropylene
General					
D-792	Specific Gravity	1.38	1.55	1.76	.905
D-570	Water Absorption % 24 Hrs. @ 73° F	.05	.05	.04	.02
Mechanical					
D-638	Tensile Strength psi @ 73° F	7,940	8,400	6,000	5,000
D-638	Modulus of Elasticity in Tension psi @ 73° F x 10 ⁵	4.2	4.2	2.1	1.7
D-790	Flexural Strength psi	14,500	15,600	9,700	7,000
D-256	Izod Impact Strength psi @ 73° F (Notched)	.65	3.0	3.8	1.3
Thermal					
D-696	Coefficient of Thermal Expansion in/in/° F x 10 ⁻⁵	3.0	3.8	7.9	5.0
C-177	Thermal Conductivity BTU/HR/Sq. Ft./° F/in	1.2	.95	.79	1.2
D-648	Heat Distortion Temp. ° F @ 66 psi	NA	238	284	220
D-648	Heat Distortion Temp. ° F @ 264 psi	160	221	194	140
	Resistance to Heat ° F at Continuous Drainage	140	210	280	180
Flammability					
D-2863	Limiting Oxygen Index (%)	43	60	44	17
E-84	Flame Spread Underwriters Lab Rating (Sub. 94)	15-20 94V-0	15 94V-0	0 94V-0	NA 94HB

Do not use or test the products in this catalog with compressed air or other gases.

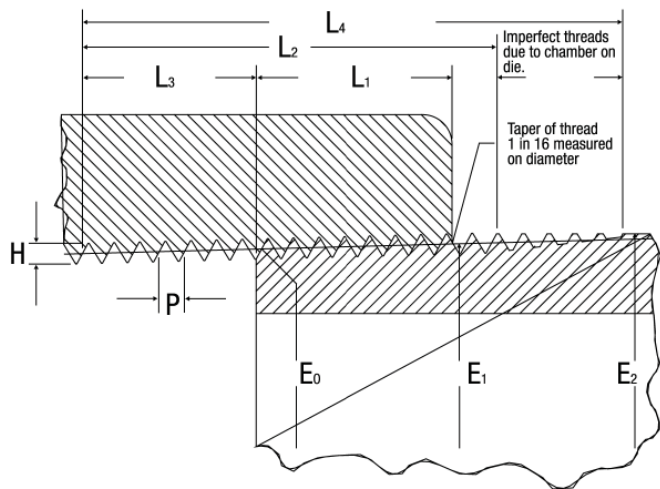

American Standard Taper Pipe Thread, NPT

Nominal Size	Outside Diameter D	Number of Threads Per Inch n	Pitch of Thread p	Normal Engagement By Hand L ₁	Length of Effective Thread L ₂
in.	in.		in.	in.	in.
1/4	0.540	18	.05556	.228	.4018
1/2	0.840	14	.07143	.320	.5337
3/4	1.050	14	.07143	.339	.5457
1	1.315	11 1/2	.08696	.400	.6828
1 1/4	1.660	11 1/2	.08696	.420	.7068
1 1/2	1.900	11 1/2	.08696	.420	.7235
2	2.375	11 1/2	.08696	.436	.7565
2 1/2	2.875	8	.12500	.682	1.1375
3	3.500	8	.12500	.766	1.2000
4	4.500	8	.12500	.844	1.3000

Do not thread Schedule 40 pipe.

For complete technical information and more, refer to our website at www.chemtrol.com.

ANSI B16.5 Dimensional Data Flanges and Flanged Fittings

Nominal Pipe Size (In.)	Outside Diameter (In.)	Dimensions†		
		Drilling Number of Holes	Diameter of Bolt (In.)	Diameter of Bolt Circle (In.)
1/2	3.50	4	1/2	2.38
3/4	3.88	4	1/2	2.75
1	4.25	4	1/2	3.12
1 1/4	4.62	4	1/2	3.50
1 1/2	5.00	4	1/2	3.88
2	6.00	4	5/8	4.75
2 1/2	7.00	4	5/8	5.50
3*	7.50	4	5/8	6.00
4*	9.00	8	5/8	7.50
6*	11.00	8	3/4	9.50
8*	13.50	8	3/4	11.75
10**	16.00	12	7/8	14.25
12**	19.00	12	7/8	17.00

* Two piece "Van Stone" Design or one piece Solid Design.

** Two piece "Van Stone" Design only.

† Dimensions and bolts conform to ANSI B16.5 for 150 lb. steel flanges. Bolt holes are 1/8" larger in diameter than the required bolts.

(excerpt from ANSI B1.20.1 Thread Specifications)

Nominal Size (in.)	Wrench Makeup Length for Internal Thread L ₃ (in.)	Total Length: End of Pipe to Vanish Point L ₄ (in.)	Pitch Diameter at Beginning of External Thread E ₀ (in.)	Pitch Diameter at Beginning of Internal Thread E ₁ (in.)	Height of Thread (Max.) h (in.)
1/4	.1667	.5946	.47739	.49163	.04444
1/2	.2143	.7815	.75843	.77843	.05714
3/4	.2143	.7935	.96768	.98887	.05714
1	.2609	.9845	1.21363	1.23863	.06957
1 1/4	.2609	1.0085	1.55713	1.58338	.06957
1 1/2	.2609	1.0252	1.79609	1.82234	.06957
2	.2609	1.0582	2.26902	2.29627	.06957
2 1/2	.2500	1.5712	2.71953	2.76216	.10000
3	.2500	1.6337	3.34062	3.38850	.10000
4	.2500	1.7337	4.33438	4.38712	.10000

Do not use or test the products in this catalog with compressed air or other gases.

Schedule 80

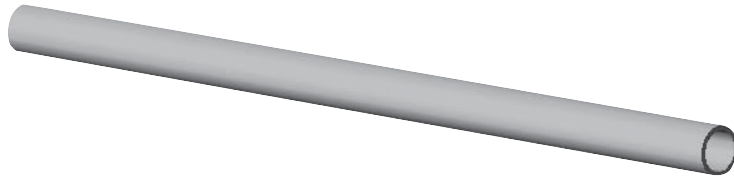

Pipe¹ 20 ft. Lengths

Nominal Pipe Size	Approximate Weight per 100 ft.				Nom. Outside Diameter (In.)	Nom. Inside Diameter (In.)	Wall Thickness (in.)		Cross-sectional Area (in. ²)	Internal Area (in. ²)	Fluid Capacity (gal/100ft.)	Outside Surf. Area (ft ² /100ft)	Threshold Flow ² (GPM)
	PVC	CPVC	Polypropylene	Kynar® PVDF			Nom.	Min.					
1/4"	10.1	11.9	----	----	.540	.282	.129	.119	.167	.062	.32	14.14	.97
1/2"	20.5	24.3	14.0	24.4	.840	.526	.157	.147	.337	.217	1.13	21.99	3.39
3/4"	27.8	32.9	18.9	33.0	1.050	.722	.164	.154	.457	.409	2.13	27.49	6.38
1"	40.4	48.5	27.1	48.7	1.315	.936	.1895	.179	.670	.688	3.57	34.43	10.72
1 1/4"	56.7	66.9	37.9	----	1.660	1.255	.2025	.191	.927	1.237	6.43	43.46	19.28
1 1/2"	68.9	81.1	44.8	81.4	1.900	1.476	.212	.200	1.124	1.711	8.89	49.74	26.67
2"	94.9	108.5	62.3	112.6	2.375	1.913	.231	.218	1.556	2.874	14.93	62.18	44.79
2 1/2"	144.9	165.4	----	----	2.875	2.290	.2925	.276	2.373	4.119	21.40	75.27	64.19
3"	193.8	221.3	126.6	256.4	3.500	2.864	.318	.300	3.179	6.442	33.47	91.63	100.40
4"	283.3	323.4	185.2	357.0	4.500	3.786	.357	.337	4.647	11.258	58.48	117.81	175.44
6"	541.1	616.8	359.9	714.3	6.625	5.709	.458	.432	8.873	25.598	132.98	173.44	398.93
8"	821.9	905.8	----	----	8.625	7.565	.530	.500	13.479	44.948	233.49	225.80	700.48
10"	1227.7	----	----	----	10.750	9.493	.6285	.593	19.985	70.778	367.68	281.43	1103.02
12"	1710.4	----	----	----	12.750	11.294	.726	.687	27.495	100.181	520.79	333.79	1562.36

1 Dimensions shown are listed in ASTM D-1785 and F-441 for PVC and CPVC Schedule 80 Plastic Pipe, respectively.
 2 Upper Threshold Rate of Flow = 5 ft./sec. fluid velocity.

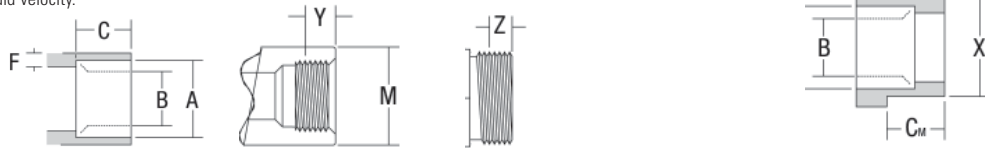

Fittings¹

Size	IPS Dia	Solvent Socket (S)			Female Threads (FPT)		Male Threads (MPT)	Male End (SPG)		Wall Thickness	
		A ³	B ³	C ⁴ Nom	Y ²	M ⁵ Min	Z ²	X	Cm ⁴ Nom	F ⁴ Min	E ⁴ Min
1/4"	.540	.552	.536	.640	.311	.840	.311	.540	.655	.149	.119
1/2"	.840	.848	.836	.890	.427	1.280	.427	.840	.905	.185	.147
3/4"	1.050	1.058	1.046	1.015	.446	1.500	.446	1.050	1.030	.195	.154
1"	1.315	1.325	1.310	1.140	.530	1.810	.530	1.315	1.155	.225	.179
1 1/4"	1.660	1.670	1.655	1.265	.550	2.200	.550	1.660	1.280	.240	.191
1 1/2"	1.900	1.912	1.894	1.390	.550	2.500	.550	1.900	1.405	.250	.200
2"	2.375	2.387	2.369	1.515	.566	2.375	.566	2.375	1.530	.275	.218
2 1/2"	2.875	2.889	2.868	1.780	.870	3.560	.870	2.875	1.810	.345	.276
3"	3.500	3.516	3.492	1.905	.954	4.300	.954	3.500	1.933	.375	.300
4"	4.500	4.518	4.491	2.280	1.032	5.430	1.032	4.500	2.310	.420	.337
6"	6.625	6.647	6.614	3.030	–	–	–	6.625	3.060	.540	.432
8"	8.625	8.655	8.610	4.500	–	–	–	8.625	4.590	.625	.500
10"	10.750	10.780	10.735	5.500	–	–	–	10.750	5.590	.741	.593
12"	12.750	12.780	12.735	6.500	–	–	–	12.750	6.590	.859	.687

1 With exception of thread lengths, dimensions shown are listed in ASTM D-2467 and F-439 for PVC and CPVC Socket-Type Schedule 80 Fittings respectively.
 2 Dimensions shown are typical male component engagement, hand tight (L₁ in ANSI B1.20.1 thread spec.) plus 1 1/2 turns lightening.
 3 Dimensions shown are not applicable for polypropylene or PVDF. Socket diameters in these materials are designed for Chemtrol thermo-seal socket fusion joining.
 4 Chemtrol fittings may exceed certain minimum ASTM dimensional requirements in order to ensure functional satisfaction.
 5 Dimensions are listed in ASTM D-2464 and F-437 for PVC and CPVC Threaded Schedule 80 Fittings, respectively.

Do not use or test the products in this catalog with compressed air or other gases.

Pressure Ratings of Chemtrol Products

Pipe and Fittings

In order to determine the pressure rating for product system, first find the plastic material and schedule (wall thickness—see Reference Data—Schedule 80 components on page 40 for additional information) of pipe and fittings in the heading of the Maximum Nonshock Operating Pressure table below. Then, locate the selected joining method in the subheading of the table and go down the column to the value across from a particular pipe size, listed in the far left column. This will be the maximum non-shock operating pressure at 73° F for the defined product system.

Maximum Nonshock Operating Pressure (psi) at 73° F¹

Nom. Pipe Size	Schedule 40							
	PVC & CPVC		Schedule 80 PVC & CPVC		Schedule 80 Polypropylene		Schedule 80 PVDF (Kynar®)	
	Socket End	Socket End	Threaded End	Thermo-Seal Joint	Threaded ³ End	Thermo-Seal Joint	Threaded End	
1/2	600	850	420	410	20	580	290	
3/4	480	690	340	330	20	470	230	
1	450	630	320	310	20	430	210	
1 1/4	370	520	260	260	20	-----	-----	
1 1/2	330	470	240	230	20	326	160	
2	280	400	200	200	20	270	140	
2 1/2	300	420	210	-----	-----	-----	-----	
3	260	370	190	190	20	250	N.R.	
4	220	320	160	160	20	220	N.R.	
6	180	280	N.R.	140	N.R.	190	N.R.	
8	160	250 ²	N.R.	-----	-----	-----	-----	
10	140	230	N.R.	-----	-----	-----	-----	
12	130	230	N.R.	-----	-----	-----	-----	

- For more severe service, an additional correction factor may be required.
 - 8° CPVC Tee, 90° ELL and 45° ELL rated at 1/2 of value shown.
 - Recommended for intermittent drainage pressure not exceeding 20 psi. Not available in natural polypropylene.
- N.R. Not Recommended

As implied by the preceding, the pressure for all thermoplastic piping is a function of temperature. For pipe and fitting applications above 73° F, refer to the table at the top of the next column for the Temperature Correction Factors. To determine the maximum non-shock pressure rating at an elevated temperature, simply multiply the base pressure rating obtained from the upper table by the correction factor from the upper table in the next column. Below 73° F the pressure rating will be the same as the base pressure in the table above.

Temperature Conversion

$$F = C \times 1.8 + 32 \quad C = (F - 32) \div 1.8$$

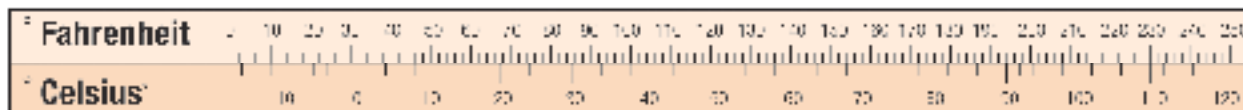

² Formerly known as Centigrade

Temperature Correction Factors

Operating Temperature (° F)	Factors PVC	CPVC	PP	Kynar® PVDF
70	1.00	1.00	1.00	1.00
80	0.90	0.96	0.97	0.95
90	0.75	0.92	0.91	0.87
100	0.62	0.85	0.85	0.80
110	0.50	0.77	0.80	0.75
115	0.45	0.74	0.77	0.71
120	0.40	0.70	0.75	0.68
125	0.35	0.66	0.71	0.66
130	0.30	0.62	0.68	0.62
140	0.22	0.55	0.65	0.58
150	N.R.	0.47	0.57	0.52
160	N.R.	0.40	0.50	0.49
170	N.R.	0.32	0.26	0.45
180	N.R.	0.25	*	0.42
200	N.R.	0.18	N.R.	0.36
210	N.R.	0.15	N.R.	0.33
240	N.R.	N.R.	N.R.	0.25
280	N.R.	N.R.	N.R.	0.18

* Recommended for intermittent drainage pressure not exceeding 20 psi. N.R. Not Recommended.

Valves, Unions, and Flanges

The maximum pressure rating for Chemtrol valves, flanges, and unions, regardless of size, is 150 psi at 73° F. As with all other thermoplastic piping components, the maximum non-shock operating pressure is related to temperature. Above 100° F refer to the chart below.

Maximum Non-Shock Operating Pressure (psi) vs. Temperature

Operating Temperature (° F)	PVC	CPVC	PP	Kynar® PVDF
73-100	150	150	150	150
110	135	140	140	150
120	110	130	130	150
130	75	120	118	150
140	50	110	105	150
150	N.R.	100	93	140
160	N.R.	90	80	133
170	N.R.	80	70	125
180	N.R.	70	50	115
190	N.R.	60	N.R.	106
200	N.R.	50	N.R.	97
250	N.R.	N.R.	N.R.	50
280	N.R.	N.R.	N.R.	25

N.R. Not Recommended.

Do not use or test the products in this catalog with compressed air or other gases.

Many commercial, industrial, and governmental standards or specifications are available to assist the design engineer in specifying plastic piping systems. Standards most frequently referred to and most commonly called out in plastic piping specifications are ASTM Standards. These standards also often form the basis of other standards in existence. Below is a list and description of those standards most typically applied to industrial plastic piping.

ASTM Standard D-1784

(American Society for Testing and Materials)

This standard covers PVC and CPVC compounds used in the manufacture of plastic pipe, valves, and fittings. It provides a means for selecting and identifying compounds on the basis of a number of physical and chemical criteria. Conformance to a particular material classification in this standard requires meeting a number of minimum physical and chemical properties.

ASTM Standards D-1785 and F-441

These standards cover the specification and quality of Schedule 40, 80, and 120 PVC (D-1785) and CPVC (F-441) pressure pipe. Outlined in these standards are dimensional specifications, burst, sustained, and maximum operating pressure requirements and test procedures for determining pipe quality with respect to workmanship and materials.

ASTM Standard D-2466

These standards cover Schedule 40 PVC (D-2466) threaded and socket pressure fittings. Stipulated in the standard are thread and socket specifications, by lengths, wall thickness, burst, material, quality, and identification requirements.

ASTM Standards D-2464 and F-437

These standards cover PVC (D-2464) and CPVC (F-437) Schedule 80 threaded pressure fittings. Thread dimensional specifications, wall thickness, burst, material quality, and identification requirements are specified.

ASTM Standards D-2467 and F-439

These standards cover Schedule 80 PVC (D-2467) and CPVC (F-439) Socket Type Pressure Fittings. Dimensions, burst strength, resin compound stipulation, and scheme of product identification requirements are specified.

ASTM Standards D-2564 and F-493

These standards set forth requirements for PVC (2564) and CPVC (F-493) Solvent Cement. The specification identifies the resin compound to be used and stipulates minimum resin content, solution viscosities, and physical performance qualities.

ASTM Standard F-656

This standard covers the requirements for primers to be used for PVC solvent cemented joints of pipe and fittings.

ASTM Standard D-2855

This standard describes the procedure for making joints with PVC pipe and fittings by means of solvent cementing.

ASTM Standard D-4101 (Formerly D-2146)

This standard covers the polymeric content and physical characteristics of PP (polypropylene) Plastic Materials for injection molding and extrusion.

ASTM Standard D-1599

This standard covers the test method for establishing the short-term hydraulic failure pressure of thermoplastic pipe, tubing, and fitting under specific temperature, time, and method of loading conditions. These test techniques are normally used for quality control.

ASTM Standard D-1598

This standard describes the test method for determining the long-term time to failure of thermoplastic pipe under constant internal pressure in a controlled environment.

ASTM Standard D-2837

This standard describes the procedure for obtaining the Hydrostatic Design Basis for all known thermoplastic pipe materials and for any practical temperature and medium. This was achieved by evaluating stress rupture data, taken from tests conforming to ASTM D-1598, for the subject material and involved specified treatment and analysis of data.

ASTM Standard D-2657

This standard covers the procedure for heat-fusion bonding of polyolefin materials.

ASTM Standard D-3222

This standard covers the polymerization method and physical properties of PVDF (polyvinylidene fluoride) Fluoroplastic Materials for molding and extrusion.

Organizations other than ASTM issue standards that are commonly encountered in industrial thermoplastic piping design. The most important of these are described below.

ANSI B1.20.1 (was B2.1)

(American National Standards Institute)

This specification details the dimensions and tolerance for tapered pipe threads. This standard is referenced in the ASTM standard for threaded fittings mentioned above. See page 39 for details.

ANSI B16.5

This specification sets forth standards for bolt holes, bolt circles, and overall dimensions for steel 150# flanges. See page 38 for details.

NSF Standard 14

(National Sanitation Foundation)

This standard provides specifications for toxicological and organoleptic levels to determine the suitability of plastic piping for potable water use. It additionally requires adherence to appropriate ASTM Standards and specifies minimum quality control programs. To meet this standard, a manufacturer must allow third-party certification by NSF of the requirements of this standard.

NSF Standard 61

This standard was developed to establish minimum requirements for the control of potential adverse human health effects from products that contact drinking water. It is intended to cover specific materials or products that come into contact with drinking water and/or contact with drinking water treatment chemicals. The primary focus of the standard is on contaminants or impurities which may be imparted indirectly to drinking water. The products and/or materials covered include, but are not limited to, process media (carbon, sand, etc.), protective materials (coatings, linings, liners, etc.), pipes and related products (pipes, tanks, fitting, etc.), and mechanical devices used in treatment/transmission/distribution systems (valves, chlorinators, separation membranes, etc.). To meet this standard, a manufacturer must allow third-party certification by NSF of the requirements of this standard. Chemtrol products have been submitted to NSF for testing. Since the standard is new and the work required is extensive, it is not known when certification of product may be expected.

Technical Service

Technical assistance regarding standards, applications, product performance, design, and installation tips is available from Technical Services Technical Information Hotline: (888) 446-4226 phone; (888) 336-4226 fax.

Chemtrol is also able to provide:

- Material and Performance Certification Letters
- Returned Product Evaluation
- Product, Installation, and Design Seminars
- Technical Reports on a Variety of Subjects

Do not use or test the products in this catalog with compressed air or other gases.

Chemtrol One-Year Limited Warranty

CHEMTROL warrants each Chemtrol pressure-rated Pipe, Valve, and Industrial Plastic Fitting to be free from defects in materials and workmanship for a period of one (1) year from the date of purchase under normal use and service within limitations recommended by it.

In the event any defect occurs which the owner believes is covered by this Warranty, the owner should immediately contact the authorized CHEMTROL distributor. The owner will be instructed to return said product at the owner's expense to CHEMTROL or an authorized CHEMTROL representative for inspection. In the event said inspection discloses to CHEMTROL's satisfaction that said product is defective, appropriate action relating to credit or replacement shall be initiated.

THIS WARRANTY SPECIFICALLY EXCLUDES INCIDENTAL AND CONSEQUENTIAL DAMAGES OF EVERY TYPE AND DESCRIPTION RESULTING FROM ANY CLAIMED DEFECT IN MATERIAL OR WORKMANSHIP INCLUDING, BUT NOT LIMITED TO, PERSONAL INJURIES AND PROPERTY DAMAGES. Some states do not allow the exclusion or limitations of incidental or consequential damages so these limitations may not apply to you.

TO THE EXTENT PERMITTED BY LAW, IMPLIED WARRANTIES OF MERCHANTABILITY AND FITNESS FOR A PARTICULAR PURPOSE ARE LIMITED IN DURATION TO ONE (1) YEAR FROM THE TIME OF PURCHASE OF SAID VALVE OR FITTING. Some states do not allow limitations in how long an implied warranty lasts, so the above limitations may not apply to you.

This Warranty gives you specific legal rights, and you may also have other rights which vary from state to state.

How to Order

Chemtrol sells its products through select stocking distributors. Our distributors are knowledgeable of plastic applications as well as schooled in the complete Chemtrol product line. **For a listing of distributors in your area, please visit our website www.chemtrol.com.**

NIBCO INC. Customer Service

World Headquarters
1516 Middlebury Street
PO Box 1167
Elkhart, IN 46515-1167 Phone: 800.343.5455
U.S.A. Fax: 800.541.3841

To the best of our knowledge the information contained in this publication is accurate. However NIBCO®/Chemtrol® does not assume any liability whatsoever for the accuracy or completeness of such information. Final determination of the suitability of any information or product for the use to be contemplated is the sole responsibility of the user. The manner of that use and whether there is any infringement of patents is also the sole responsibility of the user.

Technical Service

Our Technical Service Department is available to provide information and guidance on the suitability of Chemtrol products for specific applications. Recommendations and assistance are also available to engineering and contracting firms for installation specifications and personnel training.

Technical Service:	International Service:
Phone: 888.446.4226	Phone: +1.574.295.3221
Fax: 888.336.4226	Fax: +1.574.295.3455

www.chemtrol.com

Chemtrol® is a brand of **NIBCO**

Do not use or test the products in this catalog with compressed air or other gases.

Chemtrol® offers a premium line of quality valves, fittings, and pipe for all of your flow-control applications.

Polyvinyl Chloride (PVC)



Chlorinated Polyvinyl Chloride (Corzan® CPVC)



Typical Applications		Chemical processing, industrial plating, chilled water distribution, chemical drainage, and irrigation systems	Systems for hot corrosive liquids, hot and cold water distribution, chemical processing, industrial plating, deionized water lines, chemical drainage, waste water treatment systems, and similar applications above the temperature range of PVC
Joining Methods		Solvent cementing, threading, or flanging	Solvent cementing, threading, or flanging
Max. Service Temperature		140° F/60° C	210° F/99° C
Fittings	Schedule 80	Socket– 1/2" through 12" Threaded– 1/4" through 4"	Socket– 1/4" through 12" Threaded– 1/4" through 4", Van Stone flanges
	Large diameter	Schedules 40 and 80 10" and 12" couplings, tees, 90° and 45° elbows, reducer bushings, and Van Stone flanges	10" and 12" couplings, tees, 90° and 45° elbows, reducer bushings
Valves	Tru-Bloc/True Union ball valves*	1/2" through 6" socket, threaded, and flanged connections	1/2" through 6" socket, threaded, and flanged connections
	Tru-Bloc/True Union ball check valves	1/2" through 4" with socket, threaded, or flanged ends	1/2" through 4" with socket, threaded, or flanged ends
	Butterfly valves*	EPDM and FKM liner	EPDM and FKM liner 3" only
	Diaphragm valves	1/2" through 4" with spigot, socket, or flanged ends	1/2" through 4" with spigot, socket, or flanged ends. Also available in PVC, natural polypropylene (Chem-Pure®) and natural PVDF
	Multiport valves*	True Union 3-way/3-position; 1/2" through 2" with socket, threaded, or flanged ends	True Union 3-way/3-position multiport ball valves, 1/2" through 2" with socket and threaded ends
	Specialty valves	Angle and Y pattern: 1/4" through 1" threaded Needle and Chemcock: 1/4" threaded	
Pipe			

*For pneumatic or electric actuation.

Refer to Chemtrol Technical Manuals for pressure ratings at various temperatures.

Corzan® is a registered trademark of The Lubrizol Corporation.

Do not use or test the products in this catalog with compressed air or other gases.

<p>Polypropylene (PP)</p> 		<p>Polyvinylidene Fluoride (KYNAR® PVDF)</p> 	
<p>Black Polypropylene: Clean chemical processes, hot corrosive liquids, industrial plating, waste treatment systems</p>	<p>Natural Polypropylene: Deionized water systems, clean chemical processes, pharmaceutical operations, food processing</p>	<p>Red KYNAR® PVDF, which protects fluid medium from UV exposure, is an excellent material for general industrial applications, especially outdoor installations.</p>	<p>Natural KYNAR® (Unpigmented) PVDF is ideal for industries such as electronics, pharmaceuticals, and processed foods or beverages.</p>
<p>Thermo-seal fusion, threading, or flanging</p>	<p>Thermo-seal fusion, threading, or flanging</p>	<p>Socket heat fusion, threading, or flanging</p>	<p>Socket heat fusion, threading, or flanging</p>
<p>180° F/82° C</p>	<p>180° F/82° C</p>	<p>280° F/138° C</p>	<p>280° F/138° C</p>
<p>IPS socket type—1/2" through 6" Threaded—1/2" through 4"</p>	<p>Socket ends—1/2" through 4" Threaded—1/2" through 4"</p>	<p>IPS socket type—1/2" through 6" Threaded—1/2" through 2"</p>	<p>IPS socket type—1/2" through 6" Threaded—1/2" through 2"</p>
<p>1/2" through 4" with socket, threaded, or flanged ends</p>	<p>1/2" through 4" with socket ends</p>	<p>1/2" through 4" with socket, threaded, or flanged ends</p>	<p>1/2" through 4" with socket, threaded, or flanged ends</p>
<p>1/2" through 4" with socket, threaded, or flanged ends</p>		<p>1/2" through 4" with socket, threaded, or flanged ends</p>	<p>1/2" through 4" with socket, threaded, or flanged ends</p>
	<p>1/2" through 4" with metric spigot, IPS socket, or ANSI flanged ends.</p>		<p>1/2" through 4" with metric spigot, IPS socket, or ANSI flanged ends.</p>
<p>NIBCO socket fusion equipment for joining PP and KYNAR® (PVDF) fittings 1/2" through 6"</p>			
<p>Schedule 40 and 80 wall thicknesses</p>		<p>Schedule 40 and 80 wall thicknesses</p>	

Kynar® is a registered trademark of Arkema Inc.

Do not use or test the products in this catalog with compressed air or other gases.

